

Thank you for choosing

Panasonic **S** VHS

MODEL AG-1680

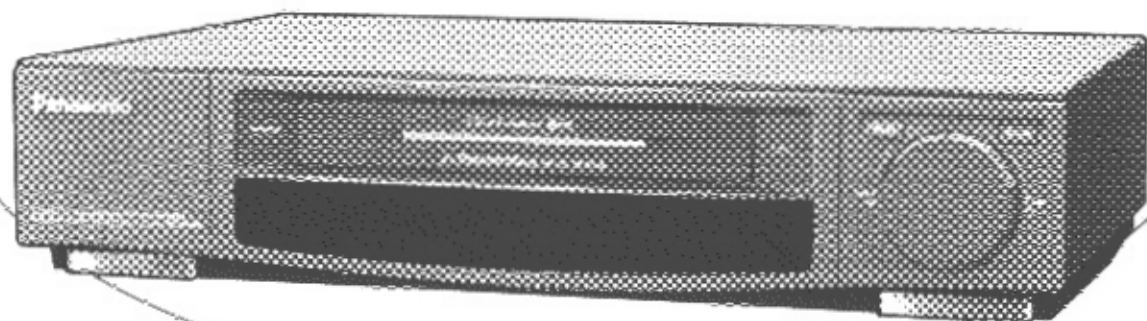

Video Cassette Recorder



Operating Instructions

Please read these instructions carefully before attempting to connect, operate or adjust this product. Please save this manual.

Spanish Quick Use Guide is included. (Guía para rápida consulta en español está incluido.)

Quick Use Guide is on the back cover.

P6 ~ P9
Connections

P10 ~ P18
Getting Started

P19 ~ P21
Basic Operation

P22 ~ P35
More You Can Do

P36 ~ Back Cover
Other Information

Things You Should Know

Congratulations

on your purchase of one of the most sophisticated and reliable products on the market today. Used properly, we're sure it will bring you and your family years of enjoyment. Please take time to fill in the information at right. The serial number is on the tag located on the back of your VCR. You'll want to keep this manual handy as your convenient VCR information source.

Date of Purchase _____
Dealer Purchased From _____
Dealer Address _____
Dealer Phone No. _____
Model No. **AG-1680** _____
Serial No. _____

Safety Precautions

Warning: To prevent fire or shock hazard, do not expose this equipment to rain or moisture.

This video recorder, equipped with the HQ System, is compatible with existing VHS equipment. Only use those tapes with the **VHS** or **SVHS** mark. It is recommended that only cassette tapes that have been tested and inspected for use in 2, 4, 6, and 8 hour VCR machines be used.

This video recorder is equipped with recording functions for both conventional **VHS** and **SVHS** systems to enable users to select either mode. An **SVHS** cassette recorded in the **SVHS** mode cannot be played back with conventional **VHS** VCRs.

FCC Warning: Any unauthorized changes or modifications to this equipment would void the user's authority to operate.

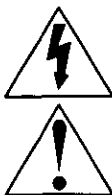
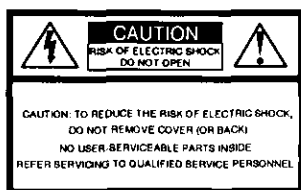

This symbol warns the user that uninsulated voltage within the unit may have sufficient magnitude to cause electric shock. Therefore, it is dangerous to make any kind of contact with any inside part of this unit.

This symbol alerts the user that important literature concerning the operation and maintenance of this unit has been included. Therefore, it should be read carefully in order to avoid any problems.

Table of Contents

| | |
|---|---|
| Important Safeguards and Precautions | 3 |
| Unpacking Your VCR • Product Features | 4 |
| VCR and Cassette Information (Record Tab, Head Cleaning, Tape Speeds, D.S.T., Specifications) | 5 |

Connections

| | |
|--|------|
| Basic Connection (Antenna and VCR, VCR and TV) | 6, 7 |
| Additional Connections (CATV, Audio/Video) | 8, 9 |

Getting Started

| | |
|--|--------|
| Location of Controls (Remote Control, VCR) | 10, 11 |
| One Time VCR Setup (Cable Box/ DSS Receiver Setup, Channel Memory, Auto Clock Set) | 12~17 |
| On Screen Displays (OSD) (Function, Channel, Menu, VCR Status & Clock, Warning, Instruction) | 18 |

Basic Operation

| | |
|---|----|
| Playback a Tape (Main Operation, Special Effects, Quality Picture Features) | 19 |
| Record On a Tape (Main Operation, One Touch Record, Channel Selection) | 20 |
| Tape Operation (Repeat Play, One Minute Skip, Zero Search, Auto Function) | 21 |

More You Can Do

| | |
|--|--------|
| Timer Recording (Main Operation, Cancel-Clear or Replace, Program Contents) | 22, 23 |
| Timer Recording Using VCR Buttons | 23 |
| Super (S) VHS System | 24 |
| Copying Your Tapes (Dubbing) (Connection, Main Operation, Monitoring, Select Input Mode) | 25 |
| Dubbing Over Your Recording (Connection, Main Operation) | 26, 27 |
| Using the 5 Pin Editing Controller | 28, 29 |
| MTS Broadcast/ VHS Hi-Fi Stereo System (Stereo/SAP/Mono Broadcast, Select Audio Mode, Spatializer) ... | 30, 31 |
| VCR Plus+ Set Up (VCR Plus+ Channel Set Up) | 32 |
| VCR Plus+ Programming (Main Operation, Make Corrections) | 33 |
| Special VCR and Remote Features (VCR Lock, Warning Beeper, Shuttle Search) | 34 |
| Multi-Brand Control Feature | 35 |

Other Information

| | |
|---|------------|
| Before Requesting Service (Self-check items) | 36, 37 |
| Spanish Quick Use Guide/Guía para rápida consulta | 38~42 |
| Quick Use Guide | Back Cover |



Important Safeguards and Precautions

FOR YOUR SAFETY, READ AND RETAIN ALL SAFETY AND OPERATING INSTRUCTIONS. HEED ALL WARNINGS IN THE MANUAL AND ON THE UNIT

INSTALLATION

1 POWER SOURCE CAUTION

Operate only from a power source indicated on the unit or in this manual.

If necessary, have your Electric Utility Service Company or Video Products Dealer verify the power source in your home.

2 POLARIZED OR GROUNDING PLUG

As a safety feature, this Video product comes with either a polarized power cord plug (one blade is wider than the other), or a three-wire grounding type plug.

POLARIZED PLUG CAUTION:

This plug will only fit into an outlet one way. If you cannot fully insert the plug, try reversing it. If it still will not fit, have an electrician install the proper wall outlet. Do not defeat the safety feature by tampering with the plug.

GROUNDING PLUG CAUTION:

This plug will only fit into a three-hole grounding outlet. If necessary, have an electrician install the proper outlet. Do not defeat the safety feature by tampering with the plug.

3 POWER CORD

Make sure power cords are routed so that they are not likely to have anything rest on them, roll over them, or be in the way of walking traffic.

If an extension cord is used, make sure it also has either a polarized or grounded plug and that the cords can be securely connected.

Frayed cords, damaged plugs, and damaged or cracked wire insulation are hazardous and should be replaced by a qualified service technician.

Overloaded outlets and extension cords are fire hazards and should be avoided.

4 DO NOT BLOCK VENTILATION HOLES

Ventilation openings in the cabinet release heat generated during operation. If they are blocked, heat build-up inside the unit can cause failures that may result in a fire hazard or heat damage to cassettes.

For protection, follow these rules:

- Never cover ventilation slots or the unit while in use, or operate the unit when placed on a bed, sofa, rug, or other soft surface.
- Avoid built-in installation, such as a book case or rack, unless proper ventilation is provided.

5 AVOID EXTREMELY HOT LOCATIONS OR SUDDEN TEMPERATURE CHANGES

Do not place the unit over or near any kind of heater or regulator, in direct sunlight, inside a closed vehicle, etc.. Do not move the unit suddenly between areas of extreme temperature variation. If the unit is suddenly moved from a cold place to a warm place, moisture may condense in the unit and on the tape.

6 TO AVOID PERSONAL INJURY

- Do not place unsecured equipment on a sloping surface.
- Support for the unit should be firm, level, and adequately strong.
- An appliance and cart combination should be moved with care. Quick stops, excessive force, and uneven surfaces may cause the appliance and cart combination to overturn.
- Carefully follow all operating instructions and use the manufacturer's recommended accessories when operating this unit or connecting it to any other equipment.



OUTDOOR ANTENNA INSTALLATION

1 SAFE ANTENNA AND CABLE CONNECTION

If an outside antenna or cable system is connected to the equipment, be sure the antenna or cable system is grounded so as to provide some protection against built up static charges and voltage surges. Section 810 of the National Electrical Code, ANSI/NFPA 70 (in Canada, part 1 of the Canadian Electrical Code) provides information with respect to proper grounding of the mast and supporting structure, grounding of the lead-in wire to an antenna discharge unit, size of grounding conductors, location of antenna discharge unit, connection to grounding electrodes and requirements for the grounding electrode.

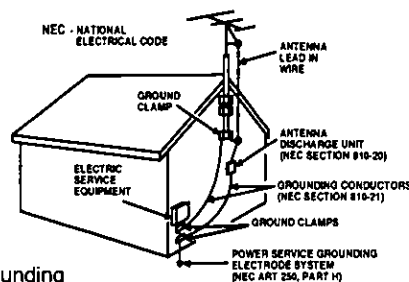

2 KEEP ANTENNA CLEAR OF HIGH VOLTAGE POWER LINES OR CIRCUITS

An outside antenna system should be located well away from power lines, electric light or power circuits and where it will never come into contact with these power sources if it should happen to fall. When installing an outside antenna, extreme care should be taken to avoid touching power lines, circuits or other power sources as this could be fatal. Because of the hazards involved, antenna installation should be left to a professional.

USING THE VIDEO UNIT

If the unit has been in storage or moved to a new location, refer first to the INSTALLATION section of these safeguards.

1 KEEP THIS VIDEO UNIT AWAY FROM WATER OR MOISTURE OF ANY KIND.

2 IF EQUIPMENT IS EXPOSED TO RAIN, MOISTURE, OR STRONG IMPACT, unplug the unit and have it inspected by a qualified service technician before use.

3 DURING AN ELECTRICAL STORM

During a lightning storm, whether indoors or outdoors, or before leaving the unit unused for extended periods of time, disconnect all equipment from the power source as well as the antenna and cable system.

4 WHEN THE UNIT IS PLUGGED IN

- Never expose the unit to rain or water. **DO NOT OPERATE** if liquid has been spilled into the unit. Immediately unplug the unit, and have it inspected by a service technician. Fire and shock hazards can result from electrical shorts caused by liquid contact inside.
- Never drop or push any object through openings in the unit. Some internal parts carry hazardous voltages and contact can cause electric shock or fire hazard.
- Avoid placing the unit directly above or below your TV set as this may cause electrical interference. Keep all magnets away from electronic equipment.

5 USING ACCESSORIES

Use only accessories recommended by the manufacturer to avoid risk of fire, shock, or other hazards.

6 CLEANING THE UNIT

Unplug the unit. Then, use a clean, dry, chemically untreated cloth to gently remove dust or debris. **DO NOT USE** cleaning fluids, aerosols, or forced air that could over-spray, or seep into the unit and cause electrical shock. Any substance such as wax, adhesive tape, etc. may mar the cabinet surface. Exposure to greasy, humid, or dusty areas may adversely affect internal parts.

SERVICE

1 DO NOT SERVICE THIS PRODUCT YOURSELF

If, after carefully following the detailed operating instructions, this Video product does not operate properly, do not attempt to open or remove covers, or make any adjustments not described in the manual. Unplug the unit and contact a qualified service technician.

2 IF REPLACEMENT PARTS ARE REQUIRED

Make sure the service technician uses only parts specified by the manufacturer, or those having the same safety characteristics as the original parts. The use of unauthorized substitutes may result in fire, electric shock, or other hazards.

3 HAVE THE SERVICE TECHNICIAN PERFORM A SAFETY CHECK

After any service or repairs to the unit, request the service technician to conduct a thorough safety check as described in the manufacturer's service literature to insure that the video unit is in safe operating condition.

Unpacking Your VCR • Product Features

Unpacking Your VCR

The accessories below are provided to help you use or set up your VCR.

Accessories

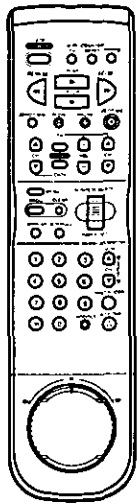

Remote Control
VSQS1462

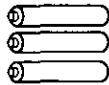

3 "AAA"
Batteries



RF Coaxial
Cable
VJAS0183

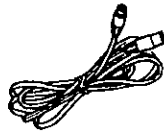

S-VHS
Connecting
Cable
VJAS0148

To order accessories,
call toll free 1-800-332-5368.

Loading the Batteries

1 Lift off the lid after pressing in and up on the latch with your thumb nail or other narrow object.

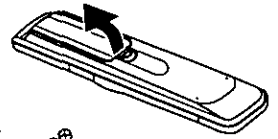

2 Install three batteries as indicated inside the Battery Compartment.

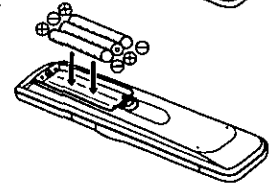

3 Fit the lid's hinge piece into the indent on the case, and snap the lid into place.

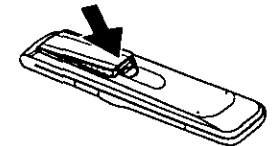

Battery replacement caution

- Do not mix old and new batteries.
- Do not mix alkaline with manganese batteries.

Product Features

| | |
|---|------------|
| 5 Pin Editing Controller | 28, 29 |
| All Channel Auto Set/ 181-CH TV/CATV Tuner | 14 |
| Advanced Noise Reduction | 19 |
| Audio Dubbing | 26 |
| Auto Clock Set | 14, 15, 16 |
| Auto Daylight Saving Time | 7 |
| Auto Operation Functions (Auto Playback, Rewind, Tape Eject, Power off) | 21 |
| Auto Repeat Function | 21 |
| Cable Box Channel Control | 13 |
| Color Noise Reduction | 19 |
| Digital Auto Picture | 19 |
| DynAmorphous™ Metal Head | 19 |
| Flying Erased Head | 26 |
| Front-mounted A/V In Terminals | 25 |
| Head Cleaner | 5 |
| MTS Broadcast System (Multi-channel Television Sound-Stereo, SAP, Mono) | 30 |
| Multi Brand TV/Cable Box Remote Control | 35 |
| One Minute Skip | 21 |
| One Month, 8 Program Timer Recording | 22, 23 |
| One Touch Recording (OTR) | 20 |
| Program Director Remote Control | 22, 23 |
| Shuttle Search | 34 |
| Spatializer | 31 |
| Special Effects Playback | 19 |
| Special VCR Features (VCR Lock, Warning Beeper) | 34 |
| Super (S) VHS System | 24 |
| VCR Plus+ Recording | 32, 33 |
| VHS Hi-Fi Stereo System | 31 |
| Video Dubbing | 27 |
| Zero Search | 21 |

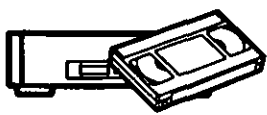

VCR and Cassette Information

Erase Protection (Record Tab)

Cassettes have a record tab to ensure that recordings are not accidentally erased.

To prevent accidental erasure, break off the tab with a screwdriver.



To record again, cover the hole with cellophane tape.



Reset all VCR Memory Functions

Use when moving the VCR to a new location, or if a mistake was made in the One Time VCR Setup section.

- Make sure a tape is not inserted in the VCR.
- 1) Turn VCR Power on.
 - 2) Push and hold both PLAY and Rewind buttons on the VCR for more than 5 seconds.
 - The power will shut off.
 - 3) Perform the One Time VCR Setup section on page 14.

Build-in Head Cleaner

A clean video head helps produce a clear picture. So, we have equipped your VCR with a built-in, non chemical head cleaning system that helps prevent clogging of the video heads. Cleaning is performed each time you load or unload a video cassette.

Note: This feature is preventative only. If your video heads are seriously clogged, consider the use of a chemical nonabrasive head cleaning kit or take your VCR to a Service Center.

Cleaning Care for Video Heads



Clogged Video Head Picture

or

Blue Back
(During playback of pre-recorded tape)

Blue Back Screen

Clogged Video Heads

While your VCR will not normally require head cleaning, however the heads may become clogged when playing an old or damaged tape. If the image on your screen resembles the illustration on the left or the screen becomes solid blue when playing back a pre-recorded signal on the tape, the heads probably require cleaning.

Cleaning the Heads

It is recommended that head cleaning be performed by a qualified service technician. Please contact your nearest Panasonic Service Center. An alternate solution is to obtain a head cleaning cassette. Be sure to follow the cleaning instructions carefully. Excessive use of a cleaning cassette could shorten head life. Use this cassette only when symptoms occur.

Maximum Record/Playback Time

Only use tapes with the **VHS** or **SVHS** mark in this unit.

| Tape Speed Setting | Type of Video Cassette | | |
|-----------------------|------------------------|---------|--------------------|
| | T60 | T120 | T160 |
| SP (Standard Play) | 1 Hour | 2 Hours | 2 Hours 40 Minutes |
| LP (Long Play) | 2 Hours | 4 Hours | 5 Hours 20 Minutes |
| SLP (Super Long Play) | 3 Hours | 6 Hours | 8 Hours |

D.S.T. (Daylight Saving Time)

Spring (First Sunday in April)

When the VCR is set to DST:ON, it automatically adds one hour and adjusts the clock.

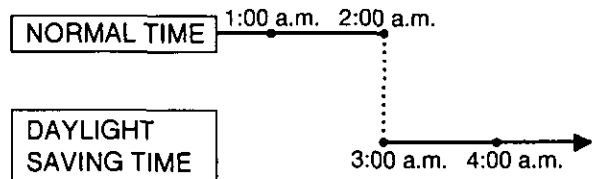

Autumn (Last Sunday in October)

When the VCR is set to DST:ON, it automatically turns back one hour and adjusts the clock.

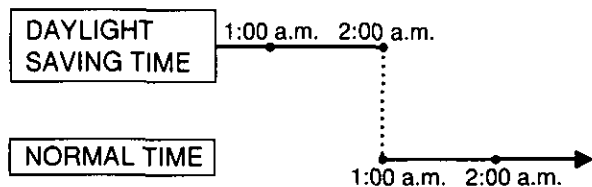

Specifications

- Power Source:** 120V AC, 60 Hz
- Power Consumption:** Approx. 28 watts (Power on)
Approx. 10.5 watts (Power off)
- Video Signal:** EIA Standard NTSC color
- Video Recording System:** 4 rotary heads helical scanning system
- Audio Track:** 1 track (Normal)
2 channel (Hi-Fi Audio Sound)
- Tuner:**
- Broadcast Channels:** VHF 2~13, UHF 14~69
- CATV Channels:** Midband A through I (14~22)
Superband J through W (23~36)
Hyperband AA~EEE (37~64)
Lowband A-5~A-1 (95~99)
Special CATV channel 5A (01)
Ultraband 65~94, 100~125
- S-VIDEO Input/ Output Level:** S-VIDEO CONNECTOR (SEPARATED YC CONNECTOR):
Y CONNECTOR 1.0 Vp-p, 75 ohm unbalanced
C CONNECTOR 0.286 Vp-p, 75 ohm unbalanced
- Operating Temperature:** 41°F~104°F (5°C~40°C)
- Operating Humidity:** 10%~75%
- Weight:** 8.8 lbs. (4.0 Kg)
- Dimensions:** 14-15/16" (W) X 3-1/2" (H) X 11-1/4" (D)
430 (W) X 89 (H) X 292 (D) mm

Note: Designs and specifications are subject to change without notice.



Basic Connection

ANTENNA

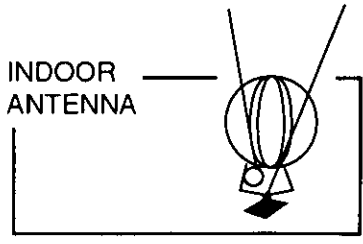

or

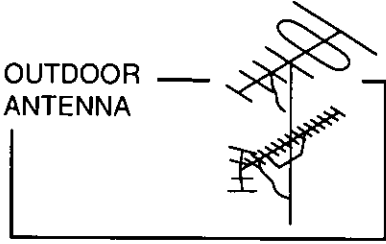

or

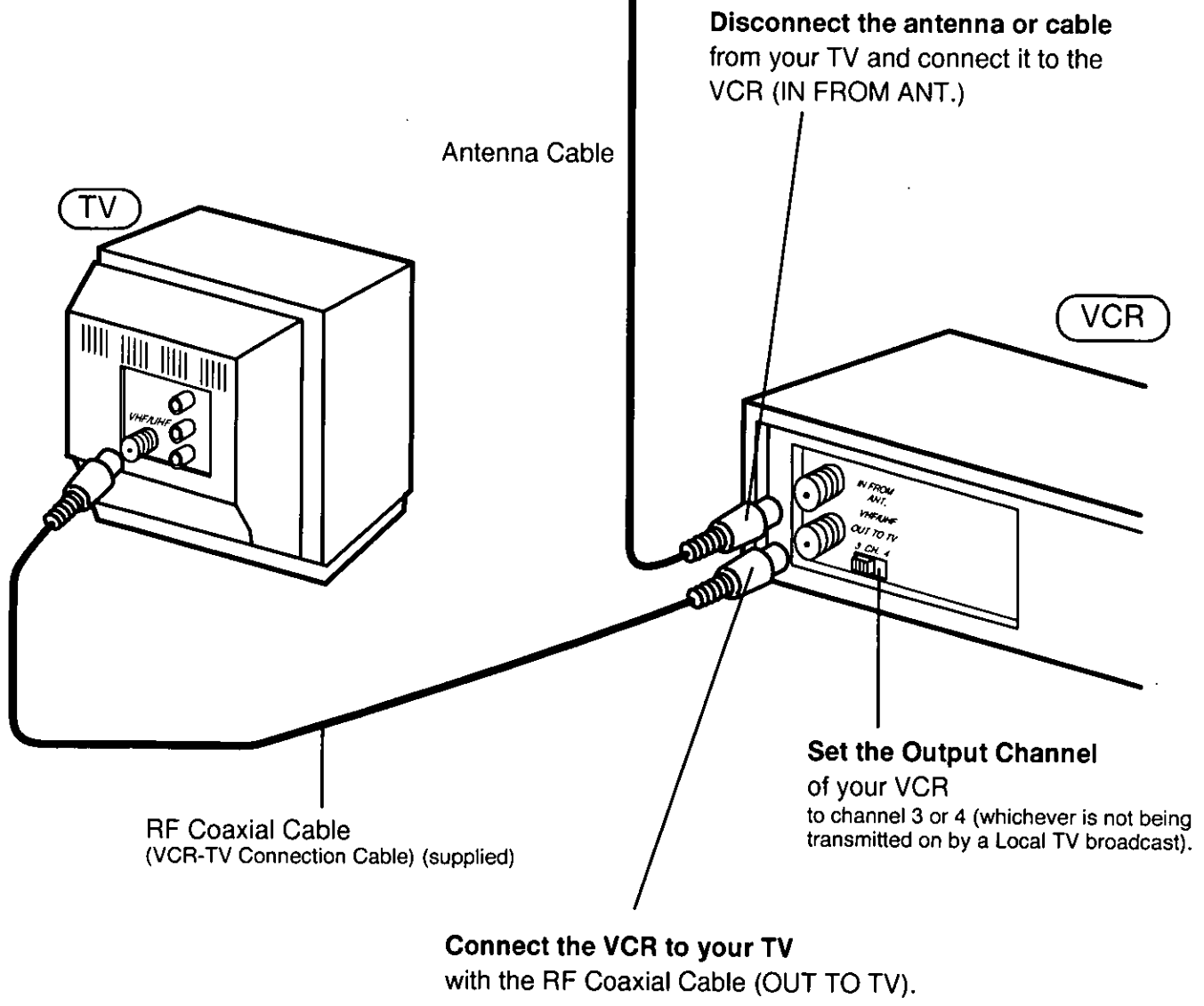
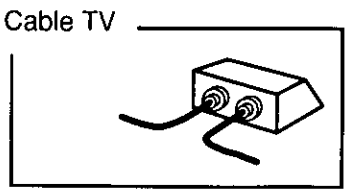

Between Antenna and VCR

Case 1: Twin Lead Cable Only

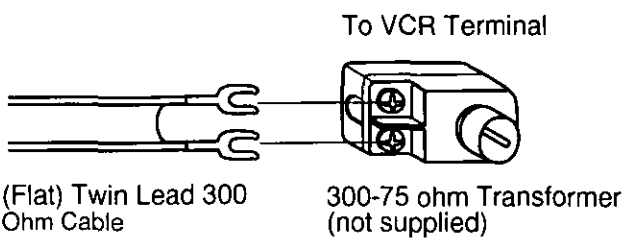

Case 2: Twin Lead & Coaxial Cables

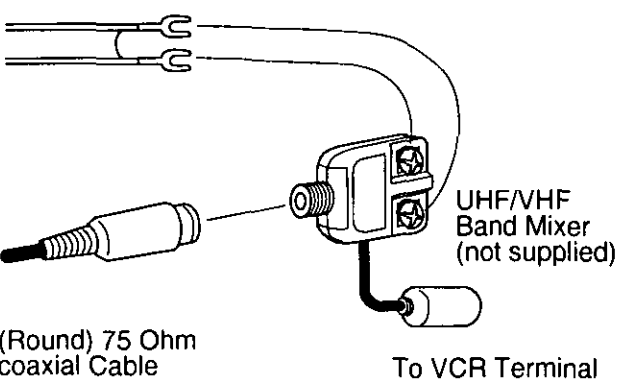

Case 3: Two Twin Lead Cables

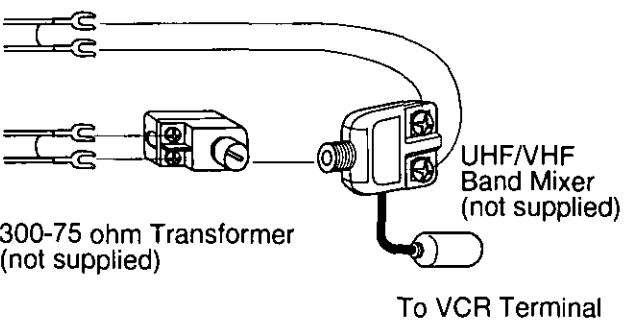

• If your TV has both post and screw-type VHF terminals, using the post connection is recommended to minimize signal loss.

Between VCR and TV

Case 1: Screw & Plug Type Terminal

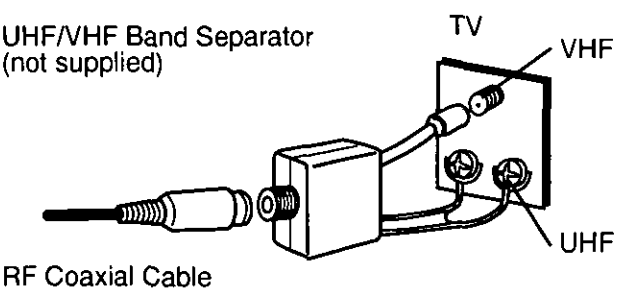

Case 2: Screw Type Terminal

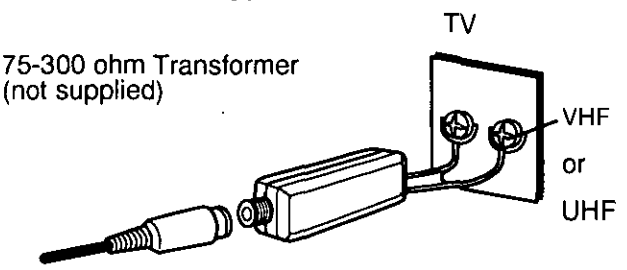

Case 3: Double Screw Type Terminal

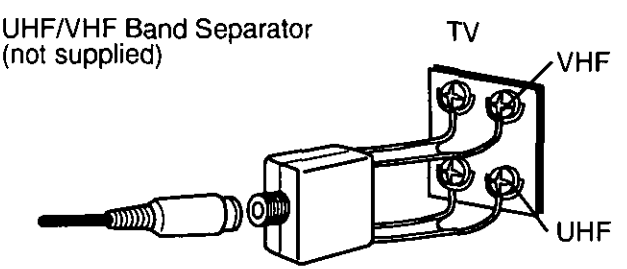

Case 4: Complex TV Terminal

TERMINALS ON BACK OF TV SET

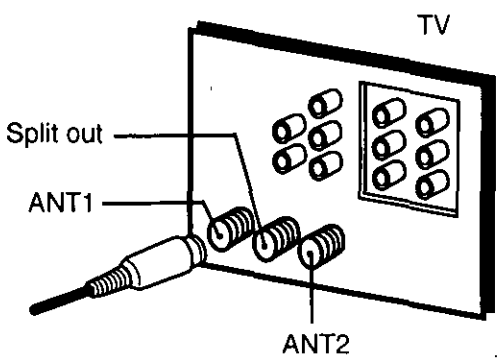

• Connect to one of the ANT terminals and select the same antenna number on the TV.



Additional Connections

CATV(Cable) Connections

All connections on this page are made with 75 Ohm coaxial cables.

Without a Converter/Descrambler Box

You can:

- 1) Use your VCR Remote Control to select channels.
- 2) Program one or more unscrambled channels for unattended recording.

NOTE: You cannot record or view scrambled channels with this connection.

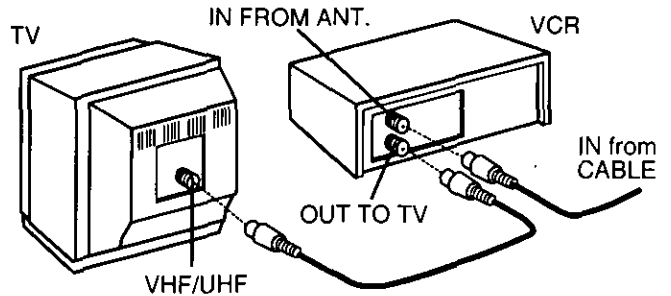

With a (CABLE to VCR) Converter/Descrambler Box

You can:

- 1) Record and view any channel including scrambled channels; channel selection must be made at the Cable TV Converter Box.
- 2) Program one channel for unattended recording.

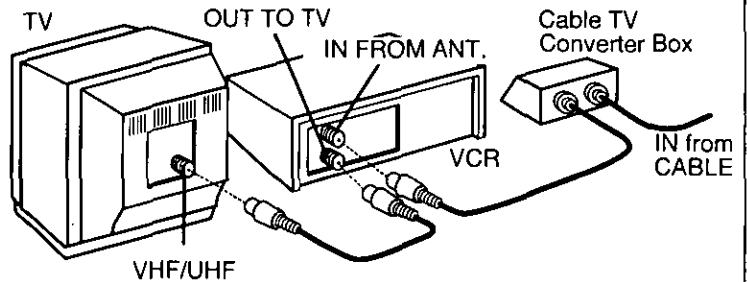

With a (VCR to TV) Converter/Descrambler Box

You can:

- 1) Use your VCR Remote Control to select channels.
- 2) Program unattended recordings of more than one unscrambled channel.

NOTE: You cannot record scrambled channels with this connection.

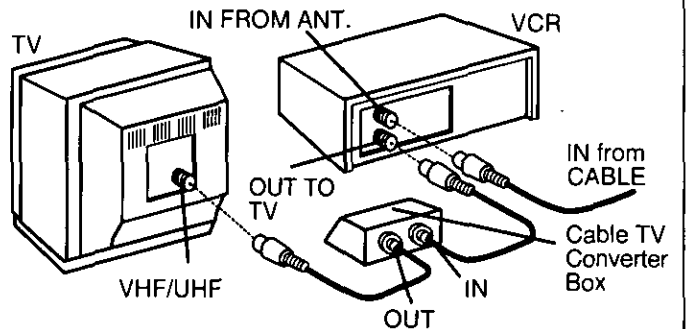

With Two Converter/Descrambler Boxes

If you want to record and view a combination of scrambled and unscrambled channels, you will need additional equipment. This connection requires two converter boxes, an A/B switch, and a 2-way splitter as shown here.

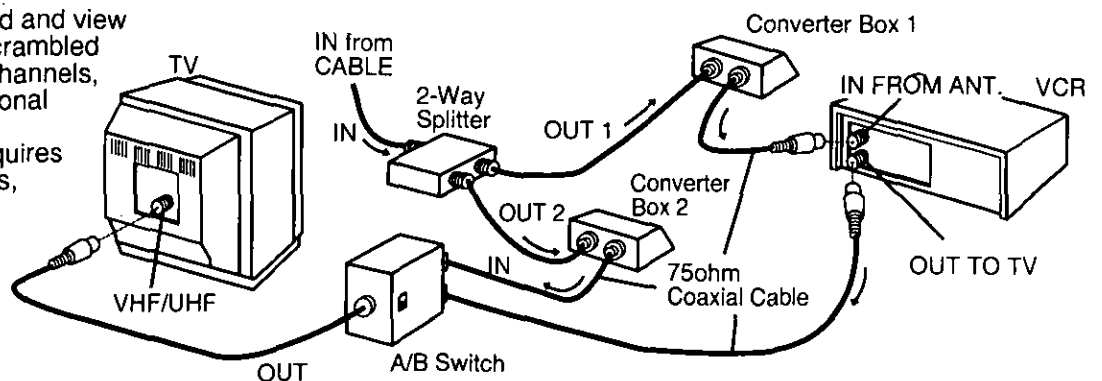

With a DSS Receiver

You can:

- 1) Record and view any channel including scrambled channels; channel selection must be made at the DSS Receiver.
- 2) Program one channel for unattended recording.

NOTE: The DSS receiver must be turned off to view programs from a cable box or antenna. See the DSS manual for details.

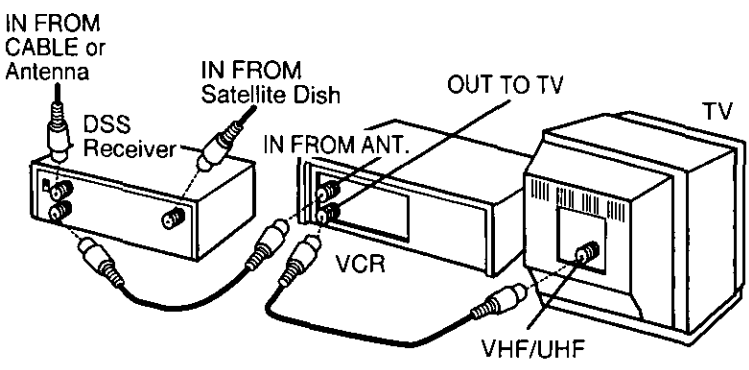

Audio/Video Connections

If your TV has AUDIO IN and VIDEO IN terminals, you can connect your VCR to them to receive a higher quality picture and sound. The antenna-VCR and VCR-TV connection is as shown.

Audio/Video Connections

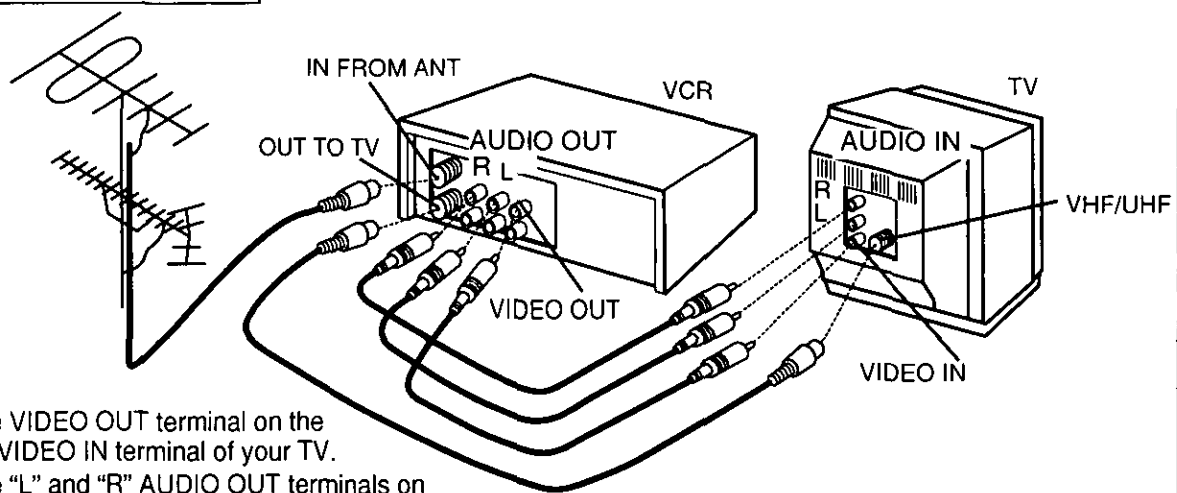

- 1 Connect the VIDEO OUT terminal on the VCR to the VIDEO IN terminal of your TV.
- 2 Connect the "L" and "R" AUDIO OUT terminals on the VCR to the "L" and "R" AUDIO IN terminals of your TV.
- 3 Set the VIDEO/TV selector of your TV (Monitor/Receiver) to "VIDEO."

NOTE: To use your TV as a VCR monitor, set the VIDEO/TV selector on the TV (Monitor/Receiver) to "VIDEO."

Stereo Amplifier Connections

When you connect your VCR to a Stereo Component System, you can view the picture from the VCR while enjoying stereo from your audio system.

Connect the "L" and "R" AUDIO OUT terminals on the VCR to the "L" and "R" AUDIO IN terminals of your stereo.

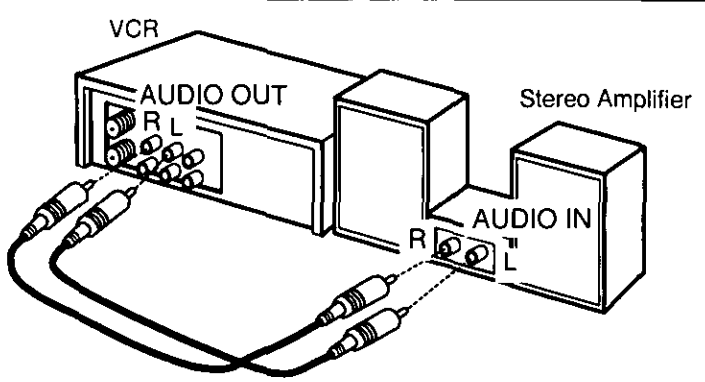

**DSS® is a registered trademark of DIRECTV, INC., a unit of GM HUGHES ELECTRONICS.

Note to CATV system installer:

This reminder is provided to call the CATV system installer's attention to Article 820-40 of the NEC in USA (and to the Canadian Electrical code in Canada) that provides guidelines for proper grounding and, in particular, specifies that the cable ground shall be connected to the grounding system of the building, as close to the point of cable entry as practical.

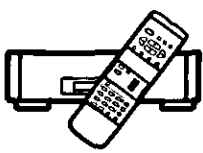

Location of Controls

Remote Control Buttons

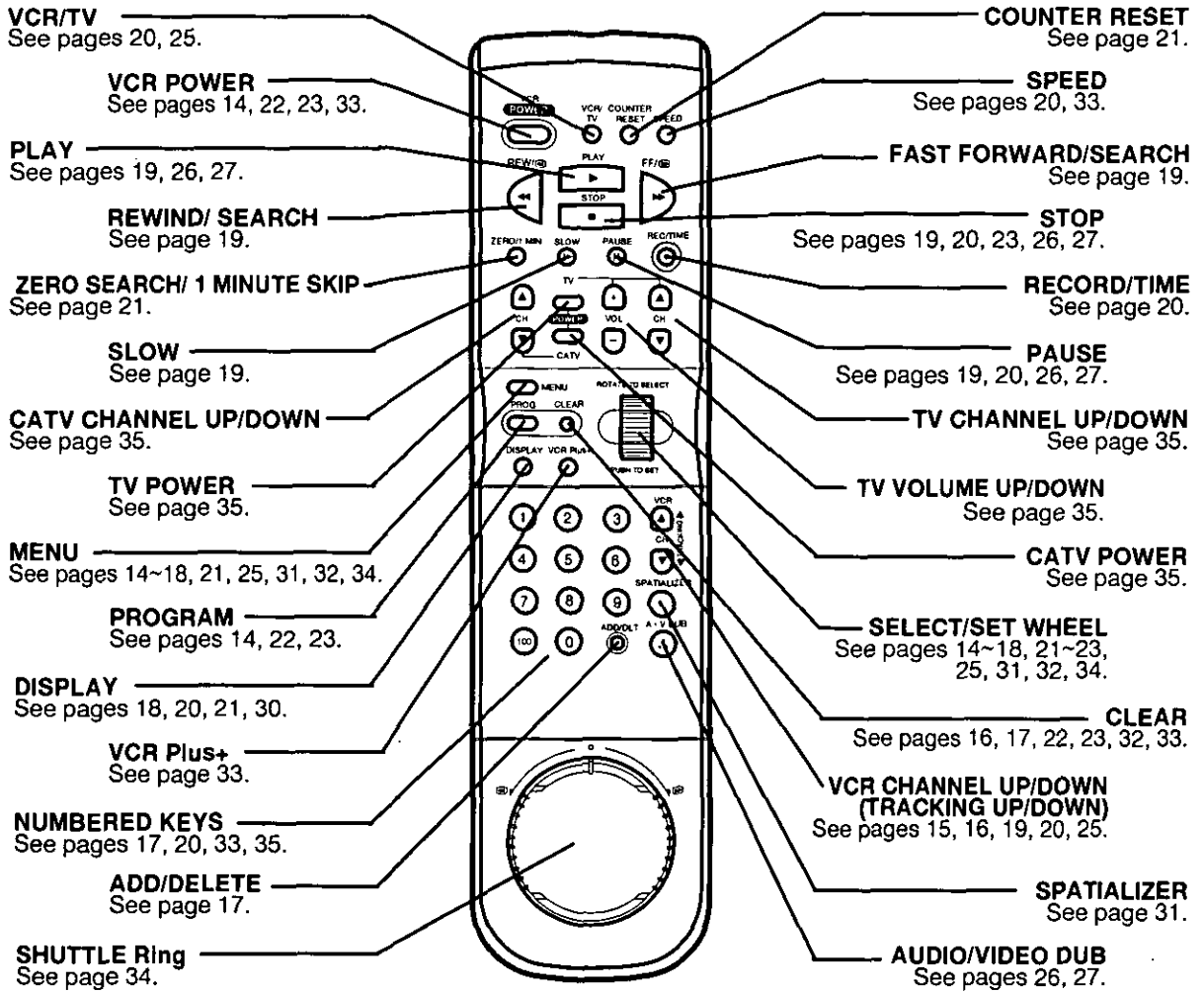

Front View of the VCR

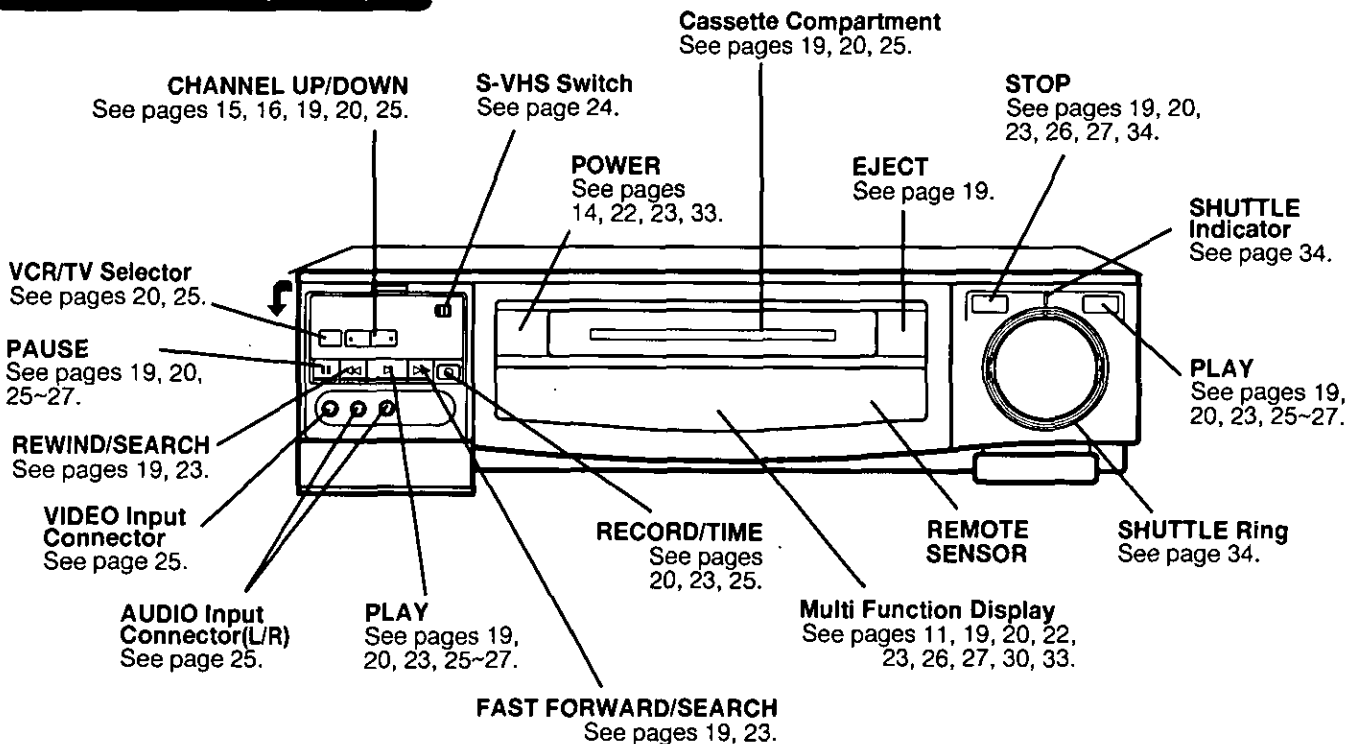

Multi Function Display

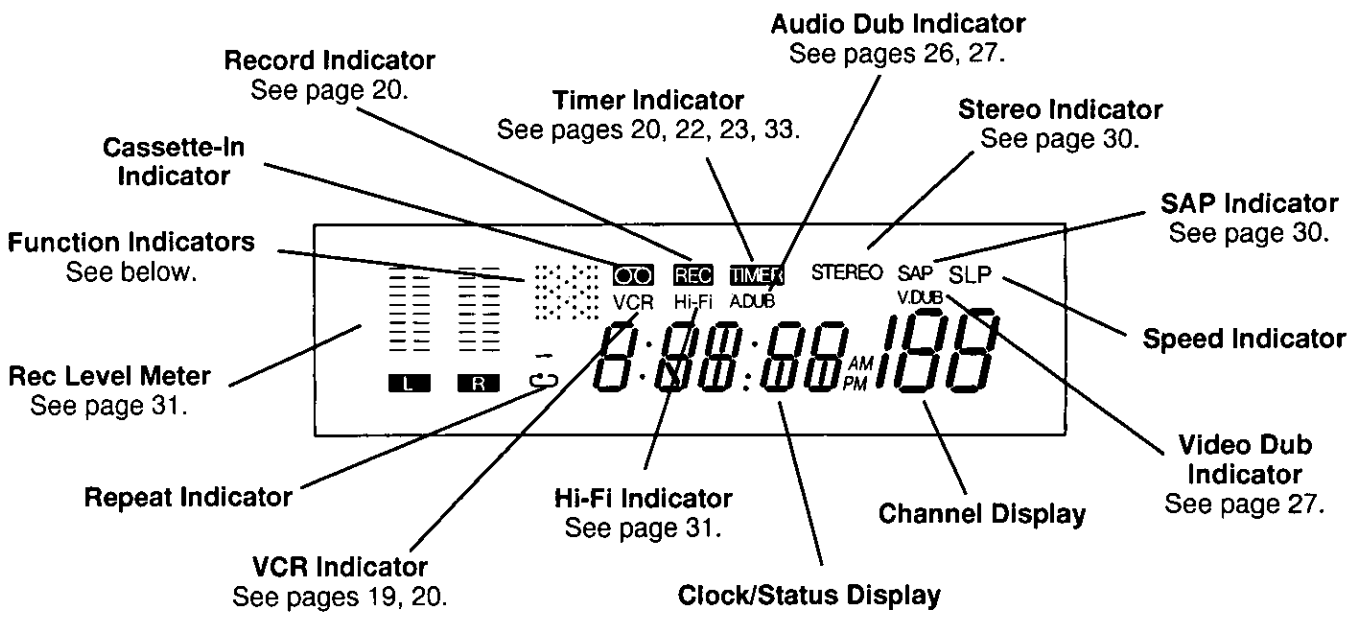

| | | | | | | | |
|---------------------|--|-----------------------------|--|---|--|---------------|--|
| Play | | Rewind/Rewind Search | | Fast Forward/Fast Forward Search | | Record | |
| Record/Pause | | Still | | Slow/Frame Advance | | Eject | |

Rear View of the VCR

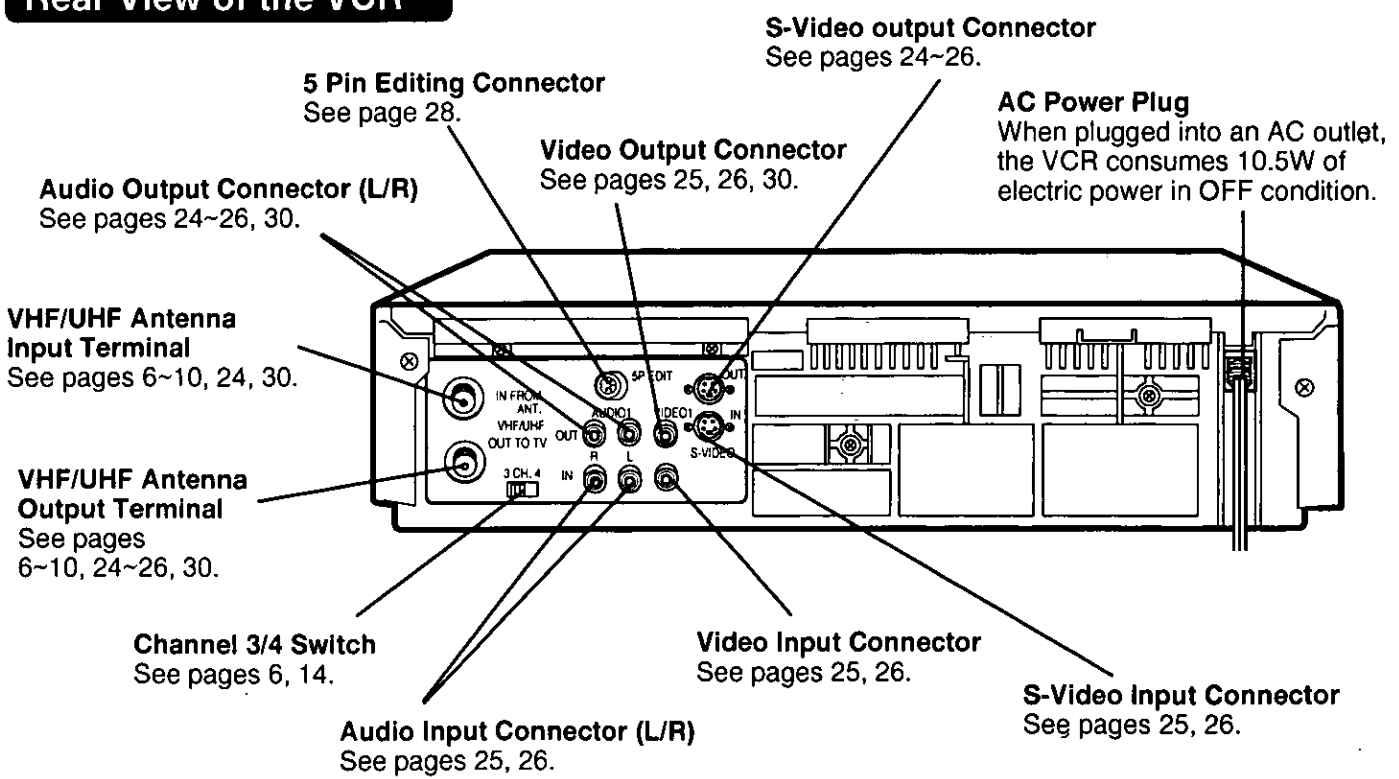



One Time VCR Setup

The setup on pages 14 through 16 is vital for proper VCR operation. Please read the instructions carefully and in the order presented.

NOTE: These first two pages contain reference material needed for setup on pages 14 ~16. Please look over the information before you begin setup procedure.

Setup Overview

You will be performing the following tasks:

- Telling the VCR what kind of equipment you are using to receive channels and how it is connected.
- Entering pertinent cable box or DSS receiver information if used.
- Entering a local PBS channel so that the VCR can receive auto clock set data. (Not available in all areas.)
- Placing channels in memory and setting the clock.

Please Note Which Connection Method You are Using.

Make sure all equipment is hooked up as described on pages 6~9.

The diagrams below illustrate some of the basic connection types. Confirm which method you used for later reference.

Connection Method 1

A. <CABLE BOX ->VCR ->TV>

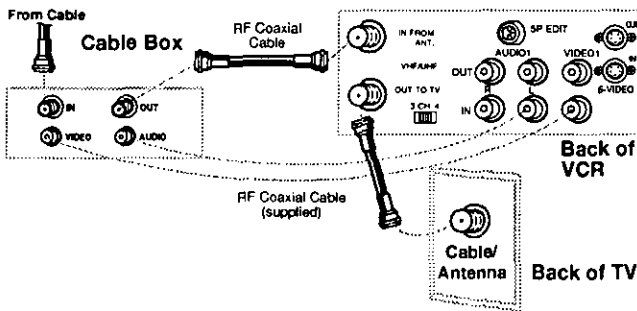

B. <ANT/CABLE BOX ->DSS BOX ->VCR ->TV>

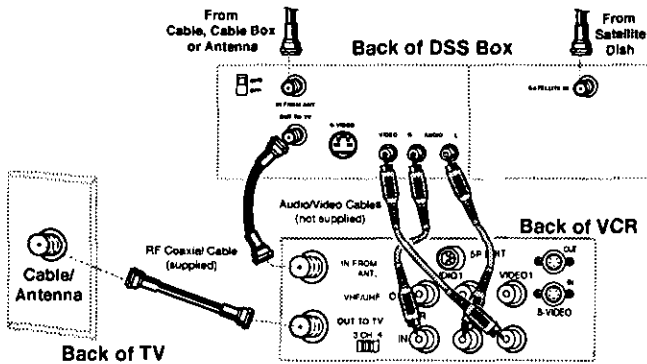

Connection Method 2

C. <VCR ->TV>

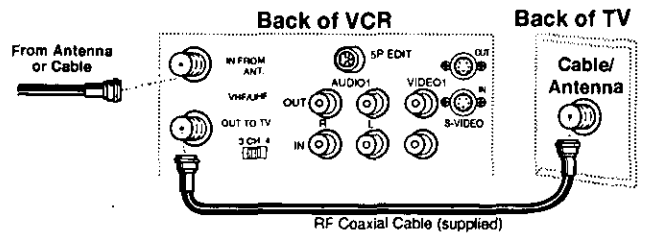

D. <VCR ->CABLE BOX ->TV>

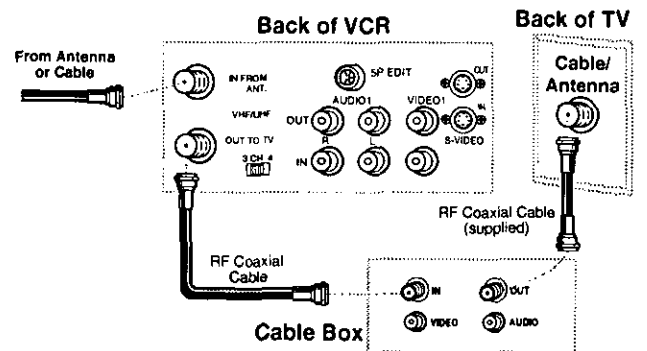

ONE TIME SETUP IMPORTANT NOTES:

- For detailed DSS receiver connection instruction, please see your DSS operating manual.
- The DSS receiver must be turned off to view programs from the cable box or antenna.
- If you use a DSS receiver, it must be turned off for auto clock set.
- If your cable box is not remote controllable, it must be tuned to your PBS channel.
- If you use Audio/Video Jack connection between the VCR and cable box or DSS receiver, you must also connect the RF coaxial cable in order to use the auto clock set and channel auto set features.

Cable Box/ DSS Receiver Code Number List

If your cable box or DSS receiver is remote controllable, refer to this list during setup on page 14.

Cable Box

| Brand | Code Numbers |
|---------------------|--|
| Archer | 01, 29, 44, 88, 91 |
| Cableview | 30, 42, 44, 52, 63, 88 |
| Citizen | 30, 42, 44, 52, 63, 88 |
| Curtis | 08, 09, 56, 61, 87, 90 |
| Diamond | 01, 29, 44, 88, 91 |
| Drake | 37, 67, 71 |
| Eagle | 13, 20, 22, 26, 40, 58, 62 |
| Eastern | 28 |
| GC Brand | 30, 42, 44, 52, 63, 88 |
| Gemini | 04, 85 |
| General Electric | 57 |
| General Instruments | |
| | 01, 02, 03, 04, 34, 55, 83, 85, 91, 93, 95 |
| Hamlin | 14, 15, 28, 41 |
| Hitachi | 31, 79 |
| Jerrold | 01, 02, 03, 04, 34, 55, 83, 85, 91, 93, 95 |
| Macom | 31, 79 |
| Magnavox | 25, 26 |
| Movietime | 32, 38, 40 |
| Movietime | 29, 32, 39, 42, 44, 88 |
| NSC | 32, 38, 40 |
| Oak | 11, 46 |
| Panasonic | 16, 17 |
| Philips | 13, 20, 23, 24, 96 |
| Pioneer | 05, 06, 78 |
| Pulser | 30, 42, 44, 52, 63, 88 |
| RCA | 16, 17 |
| Realistic | 44, 51, 88 |
| Regal | 14, 41 |

| Brand | Code Numbers |
|---------------------|----------------------------|
| Regency | 28 |
| Rembran | 29, 32, 39, 42, 44, 88 |
| Salora | 68, 72 |
| Samsung | 32, 40, 42, 78, 94 |
| Scientific Atlantic | 08, 09, 56, 61, 87, 90 |
| Sheritech | 27 |
| SL Marx | 32, 40, 42, 78, 94 |
| Sprucer | 16, 17 |
| Stargate | 32, 40, 42, 78, 94 |
| Stargate | 30, 42, 44, 52, 63, 88 |
| Sylvania | 19 |
| Telecaption | 77, 92 |
| Teknika | 74 |
| Televue | 32, 40, 42, 78, 94 |
| Texscan | 18, 19 |
| Tocom | 01, 33, 34, 42, 48, 49, 91 |
| Toshiba | 36 |
| Uniden Satellite | 65, 69 |
| Unika | 01, 29, 44, 88, 91 |
| Universal | 42, 43, 44, 52, 63, 88 |
| Viewstar | 13, 20, 22, 26, 40, 58, 62 |
| Vid Tech | 64 |
| Vidter | 64 |
| Videoway | 07, 23, 50 |
| Zenith | 07, 23, 50 |

DSS (Digital Satellite System Receiver)

| | |
|-----------|-----|
| Sony | 98 |
| RCA | 99 |
| Panasonic | 100 |

Note: During setup you will be instructed to enter your brand code number. As some brands have multiple codes, it may be necessary to try different codes to attain the proper results. These codes are for Cable box or DSS Box setup for Auto Clock and VCR Plus+ recording only. For TV/Cable Box Universal Remote Control operation, please see page 35.

Positioning Your Cable Box or DSS Receiver

If your cable box or DSS receiver is remote controllable, place it on or near the VCR as shown in the example below. The VCR transmits an infrared signal from two locations. Be sure not to cover the transmitter windows.

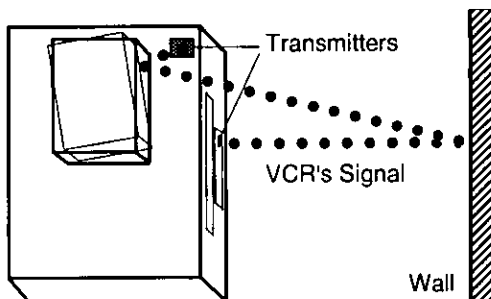



One Time VCR Setup

Follow along in the manual as you are guided through the setup procedure on the screen.

- If you make a mistake, see the "Reset all VCR Memory Function" section on page 5.



Check list before you begin.

- All TV and VCR connections are made. (See pages 6-9.)

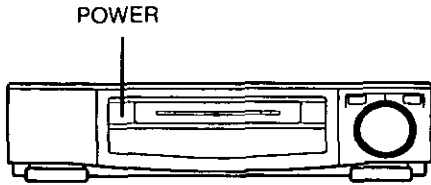

Cable box/ DSS receiver Setup, Channel Memory, and Auto Clock

- 1** Turn the TV and VCR power on.

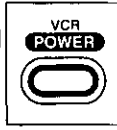

- 2** Tune your TV to the VCR channel (the same channel you set on the back of the VCR, CH3 or CH4). (See page 6.)

- 3** Push MENU for YES or PROG for NO.

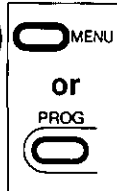

If YES, continue with next step.
If NO, go to Alternate Instructions on page 16.

ARE YOU USING A CABLE BOX OR DSS RECEIVER?

PUSH MENU KEY : YES
PUSH PROG. KEY : NO

- 4** Rotate and push the WHEEL to select your equipment connection method. (Refer to page 12.)
If "CABLE/DSS BOX- VCR- TV," go to next step.
If not, go to Alternate Instructions on page 16.

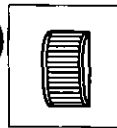

- CABLE/DSS BOX SET UP -
SELECT YOUR CABLE BOX OR DSS RECEIVER SET UP.

CABLE/DSS BOX-VCR-TV
VCR-CABLE/DSS BOX-TV

SELECT : ROTATE WHEEL
SET : PUSH WHEEL
END : PUSH MENU KEY

- 5** Rotate and push the WHEEL to set your Cable box or DSS receiver output channel. (the channel you tune the TV to in order to watch cable or DSS stations).

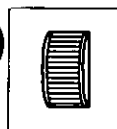

- CABLE/DSS BOX SET UP -
ENTER CABLE BOX OR DSS RECEIVER OUTPUT CHANNEL.

01

SELECT : ROTATE WHEEL
SET : PUSH WHEEL
END : PUSH MENU KEY

- If both a cable box and DSS receiver is used, set the output channel of the DSS receiver.
- If you are using Audio/Video jack connections, set VIDEO OUT as the output channel.

- 6** Rotate and push the WHEEL to select YES or NO.

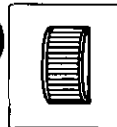

If YES continue with next step.
If NO, go to Alternate Instructions on page 16.

- CABLE/DSS BOX SET UP -
DOES YOUR CABLE BOX OR DSS RECEIVER HAVE WIRELESS REMOTE CONTROL?

YES

NO

SELECT : ROTATE WHEEL
SET : PUSH WHEEL
END : PUSH MENU KEY

- 7** Rotate and push the WHEEL to set the Cable box or DSS receiver code number that matches your brand from the list on page 13.

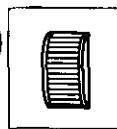

• This determines whether the VCR will control your cable box or DSS receiver.

- CABLE/DSS BOX SET UP -
CHOOSE A CODE NUMBER FOR CABLE BOX/DSS RECEIVER FROM THE LIST IN OWNER'S MANUAL AND ENTER NUMBER.

02

SELECT : ROTATE WHEEL
SET : PUSH WHEEL
END : PUSH MENU KEY

Using the Select/Set Wheel

There are basically two types of Wheel operation.

- Selecting items from an on-screen display.
- Entering information, such as setting the clock.

OPERATION

- 1** Rotate (up or down) **2** Push (like a button)

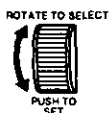

to make selection

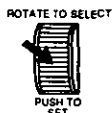

to enter selection

8 If you use a cable box, tune it to channel 02.
If you use a DSS receiver, tune it to any channel other than 200.



Push the WHEEL to continue.

If Cable Box
- CABLE/DSS BOX SET UP -
PLEASE TUNE YOUR CABLE BOX TO CH02.

If DSS Receiver
PLEASE TUNE YOUR DSS RECEIVER TO CH 270.

PROCEED : PUSH WHEEL
END : PUSH MENU KEY

9 Rotate and push the WHEEL to select YES or NO.

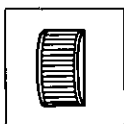

If you use a cable box and selected YES, go to step 10.
If you use a DSS receiver and selected YES, go to the Alternate Instructions on page 16.
If NO, the screen in step 7 will reappear. Try entering a different code assigned to your brand and/ or repositioning the equipment (see page 13).
If the answer is still NO, cable box or DSS receiver control is not available. Push MENU and go to the Alternate Instructions on page 16.

If Cable Box
- CABLE/DSS BOX SET UP -
IS YOUR CABLE BOX RECEIVING CH 09 ?

YES
NO

If DSS Receiver
IS YOUR DSS RECEIVER RECEIVING CH 200?

YES
NO

SELECT : ROTATE WHEEL
SET : PUSH WHEEL
END : PUSH MENU KEY

10 Rotate and push the WHEEL to select and set the local PBS channel number you receive on your cable box.

- If you live near a different time zone, enter the channel in your time zone.

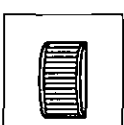

----- SET CLOCK -----
PLEASE ENTER YOUR LOCAL PBS CHANNEL ON CABLE BOX

CH 12

SELECT : ROTATE WHEEL
SET : PUSH WHEEL
END : PUSH MENU KEY

11 Confirm that your cable box is on and that your DSS Box is off. Push the WHEEL to start CHANNEL AUTO SET and AUTO CLOCK SET.

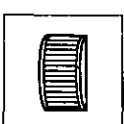

The following displays appear in sequence:
"CH AUTO SET PROCEEDING"
"CH AUTO SET COMPLETED"
"AUTO CLOCK SET PROCEEDING"

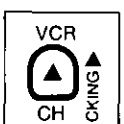

This display appears when auto clock set is completed. Confirm that the time is correct and push VCR CH ▲ to exit.

7/25/1997 FRI 12:00PM
DST:ON
SETTING : CH02
AUTO CLOCK SET
COMPLETED
END : PUSH CH UP KEY

If the Auto Clock Set displayed time is incorrect

If you use a cable box and receive more than one PBS station, try auto clock set again. Follow the Set or Reset Auto Clock Set steps and when the instructions call for you to enter a PBS station, make sure to enter the one you have not tried yet.

If AUTO CLOCK SET IS INCOMPLETE appears

The screen below will appear on-screen if auto clock set data is not available in your area.

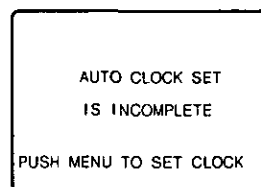

Push MENU to display the manual clock set screen. (See the "Manual Clock Set" section on page 16.)

Note:

If you use a cable box and receive more than one PBS station, you may exit the manual clock set screen and try auto clock set again.

Follow the Set or Reset Auto Clock Set steps and when the instructions call for you to enter a PBS station, make sure to enter the one you have not tried yet.

- Auto clock set will be performed when the VCR is turned off for the first time each day. If you use a cable box and you want auto clock set to be performed, the cable box must be left on at the time the VCR power is turned off.

One Time VCR Setup

Alternative Instructions

Complete the following steps if, during one time setup, any of the following applies:

- A You selected NO in step 3 on page 14 (you do not use a cable box or DSS receiver).
- B You selected connection method 2 (VCR-CABLE DSS BOX- TV) in step 4 on page 14.
- C You selected NO in step 6 on page 14 (your cable box or DSS receiver is not remote controllable).
- D You use a DSS receiver and selected YES in step 9 on page 15.
- E Cable Box or DSS receiver can not be controlled in step 9 on page 15.

1 Turn on the cable box and set it to the local PBS channel.

- If you live near a different time zone, make sure to set the channel in your time zone.
- If you use a DSS receiver, it must be turned off.

CHANNEL/CLOCK AUTO SET

CONNECT ANTENNA CABLE AND IF YOU USE A CABLE BOX, TUNE IT TO YOUR LOCAL PBS CH THEN...

PLEASE PUSH CH UP KEY

2 Push VCR CH ▲ to start CHANNEL AUTO SET and AUTO CLOCK SET.

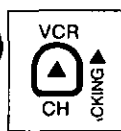

The following displays will appear in sequence.
 "CH AUTO SET PROCEEDING"
 "CH AUTO SET COMPLETED"
 "AUTO CLOCK SET PROCEEDING"

This screen appears to confirm that auto clock set is completed.

3 Confirm that the time is correct and push VCR CH ▲ to exit this screen.

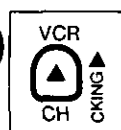

7/25/1997 FRI 12:00PM
 DST:ON
 SETTING : CH02
 AUTO CLOCK SET
 COMPLETED
 END : PUSH CH UP KEY

If this screen appears, auto clock set is not available in your area. Please set the clock manually as described at right.

AUTO CLOCK SET
 IS INCOMPLETE
 PUSH MENU TO SET CLOCK

If the displayed auto clock set time and D.S.T. are not correct

If you live close to two different time zones, the VCR may recognize the wrong PBS station as the setting channel. If this happens, please complete the following steps.

- 1 Make a note of the SETTING: CH number on screen and push VCR CH ▲ to exit.
- 2 Delete the setting channel from channel memory. (See the Add or Delete a Channel section on page 17.)
- 3 Push MENU button to display the menu.
- 4 Use the Wheel to select "SET CLOCK" and then to select "AUTO SET."
 - If you use a cable box and have multiple PBS stations, tune the cable box to a different PBS station and try auto clock set again using the menu.

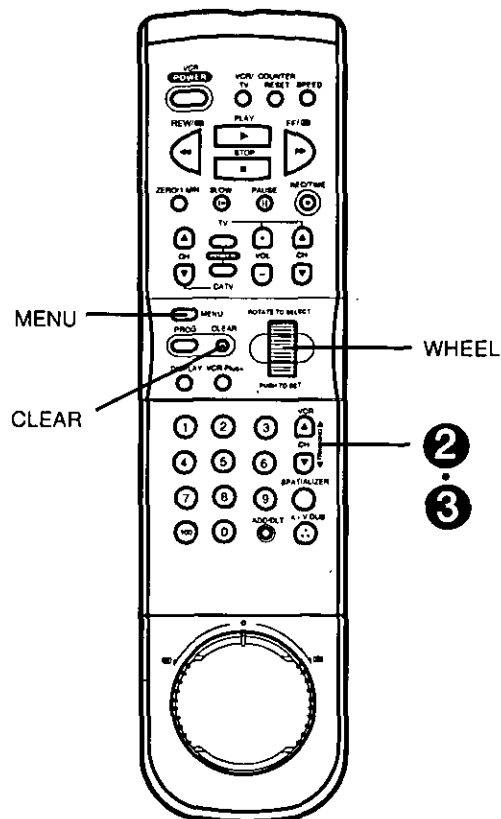

Manual Clock Set

(In case Auto Clock Set could not be performed)

1 Push MENU to display the set clock screen.

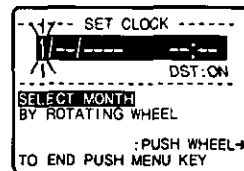

2 Rotate and push the Wheel to select and enter the month, date, year, time and D.S.T. (Daylight Saving Time).

- "DST:ON" automatically adjusts for daylight saving time. (See page 5.)

To Make Corrections, push the Wheel or CLEAR button repeatedly to move back or forward to the desired item.

3 Push MENU twice to start the clock and exit this mode.

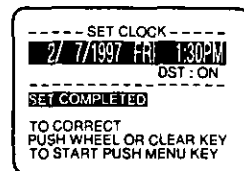

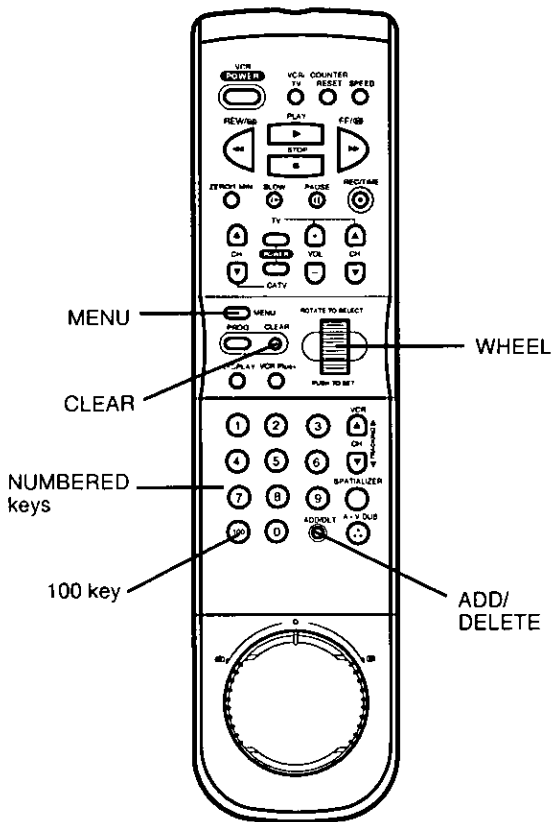

When Using the 100 key

When selecting CATV channels 100 to 125 with the NUMBERED keys, first push the 100 key and then enter the remaining two digits.
For example, to select channel 125:
Push NUMBERED keys 100, then 2, then 5.

To Set or Reset the Clock

In case the clock is wrong, or a power failure occurred.

1 Push MENU to display the menu.

2 Rotate and push the Wheel to:

- (A) Select SET CLOCK
- (B) Select MANUAL SET
- (C) Set the date, time, and D.S.T. (Daylight Saving Time).

3 Push MENU twice to start the clock and exit this mode.

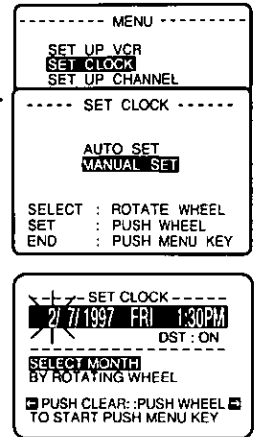

To Set or Reset Auto Clock Set

Complete the following steps if:

- Auto clock set displayed time was incorrect.
- Auto clock set was not available at the time one time setup was done, but is available now.
- The PBS channel over which clock data is sent was changed by the broadcast company.

1 Push MENU to display the menu.

2 Rotate and push the Wheel to select SET CLOCK and then select AUTO SET.

3 Follow the one time setup instructions on page 14~16.

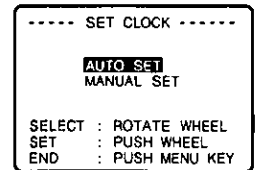

To Add or Delete a Channel

1 Select a channel using the NUMBERED keys.

2 Push ADD/DLT to add or delete the channel.

- To select a deleted channel, use the NUMBERED keys on the remote control. Deleted channels will flash in the Multi Function Display when selected.

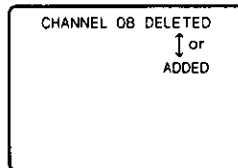

To Replace Channels in Memory

Example, if you have cable installed, etc.

1 Push MENU to display the menu.

2 Rotate and push the Wheel to select SET UP CHANNEL from menu, and then push to set your antenna system (TV or CATV).

3 Rotate and push the Wheel to select AUTO SET.

- To exit this mode, push MENU twice.

4 Follow the one time setup instructions on page 14~16.

- Whenever channels are replaced in memory, auto clock set is also reprogrammed.

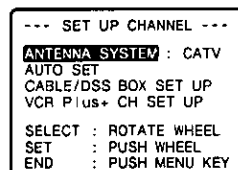
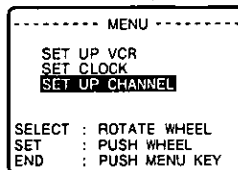

To setup the VCR in case a cable box or DSS receiver was installed or replaced

1 Push MENU to display the menu.

2 Rotate and push the Wheel to select SET UP CHANNEL from menu.

3 Rotate and push the Wheel to select CABLE/DSS BOX SET UP.
• To exit this mode, push MENU twice.

4 Rotate and push the Wheel to select YES and continue with steps 4~9 on pages 14 and 15.

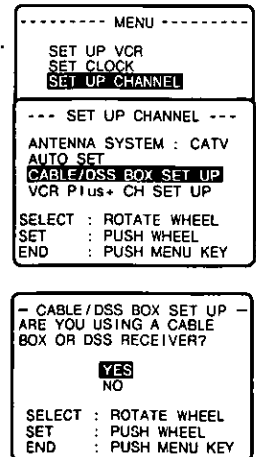

- This VCR will accurately maintain its calendar up to Dec. 31, 2014, 11:59PM.
- Normal TV or Cable channels are automatically selected and placed in memory depending on how your VCR is hooked up.
- By pushing the Wheel or CLEAR button repeatedly, you can skip forward or backward over correct entries and go directly to a specific item.

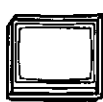

On Screen Displays (OSD)

Channel & Function Display

Whenever the channel is changed, the Channel number will appear for a few seconds on-screen. (Some station names may also appear.)

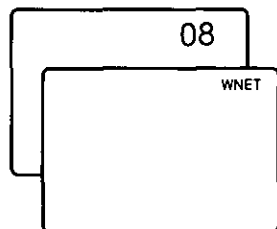

When a function button is pushed (PLAY, FF, etc.) the VCR mode will be displayed.

Menu Screen

1 Push MENU to display the menu.

2 Rotate and push the wheel to make your selection (see page 14).

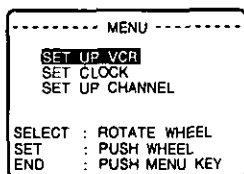

- To get the most from each feature, it is recommended that you read the Operation Manual before attempting any operation.

Warning and Instruction Displays

These displays will alert you to a missed operation or provide further instructions.

If no active channels are found for CHANNEL MEMORY...

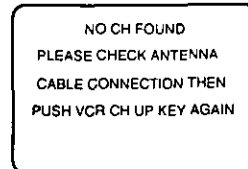

If you attempt to set or review a Timer Recording and the Clock is not set...

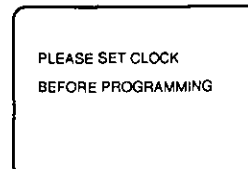

If a Timer Program was not completed before exiting the Program mode...

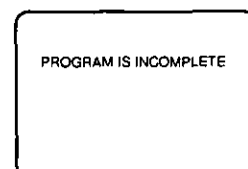

After a Timer Program has been set...



If you push REC on the remote control or REC and PLAY on the VCR, and a cassette is inserted with no record tab...

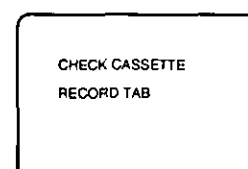

If you push PLAY, FF, REW, or REC on the remote control or if you push REC and PLAY, PLAY, FF, REW, or REC on the VCR without a cassette inserted...

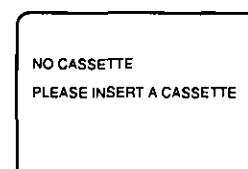

If you push POWER or STOP during a Timer Recording... (visible in VCR mode only)

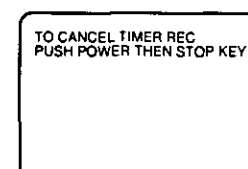

VCR Status & Clock Display

Push DISPLAY to display and remove the overlay shown below.

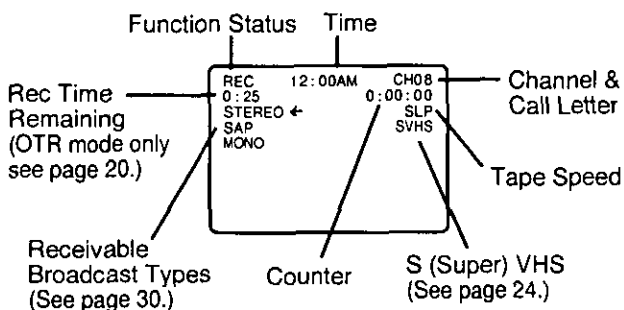

Blank Tape and will be Blue Screen

If a blank section of tape is encountered in the Play mode or the channel you select has no broadcast, the TV screen will change to a solid blue field. The screen will remain blue until a recorded signal is again detected or an active channel is selected.

▶ Playback a Tape

✓ Check list before you begin

- All connections are made. (See pages 6~9.)
- TV and VCR are plugged in.
- TV is turned on and set to the VCR channel (CH 3 or 4).

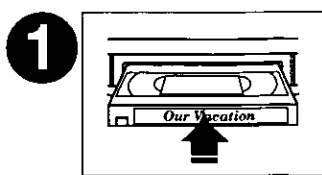
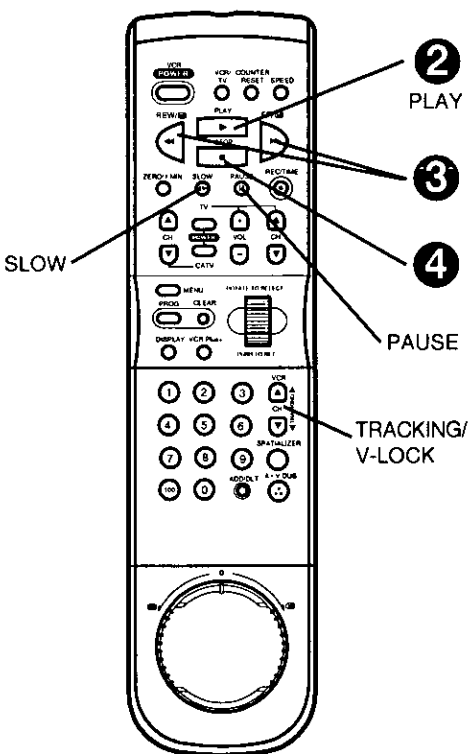
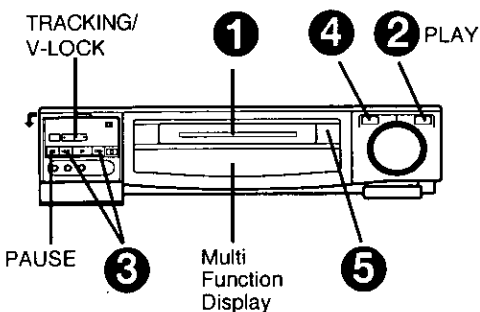

1 Insert a cassette.
• VCR power comes on automatically.

This indicator lights in the Multi Function Display.

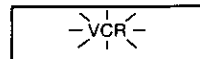

2 Push **PLAY** to start playback.

- Playback begins automatically if cassette has no record tab.

(VCR or Remote Control)

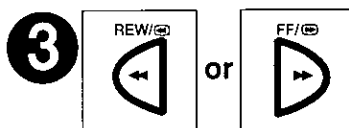

3 Push **REW** or **FF** to quickly locate a scene.

- SP mode tapes have a search speed of 9 times and SLP mode tapes 27 times the normal speed.
- Some noise bars will appear during search.

(VCR or Remote Control)

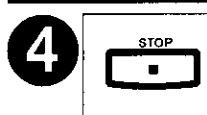

4 Push **STOP** to stop playback.

(VCR or Remote Control)



5 Push **EJECT** to eject the cassette.

- This button only on VCR.

Special Effects During Playback

These features work best in SP or SLP mode. The sound will be muted. (After the VCR is in the Still or Slow mode for 3 minutes, it will go into the Stop mode automatically to protect the tape and video head.)

Slow Motion Playback

Push **SLOW** to start and **PLAY** or **SLOW** to release the Slow mode.

Still (Freeze) Frame Picture

Push **PAUSE** to freeze and release the picture.

- To reduce picture noise:
Place the VCR in Slow motion mode. Use **TRACKING** ▲/▼ to clear up the picture, then push **PAUSE**.

Frame by Frame Advance

While in Still mode, hold down **SLOW** to advance the still picture one frame at a time. Push **PAUSE** to release.

Feature for a Quality picture

Digital Auto Picture

This feature automatically controls the video output signal for less noise depending on the tape condition.

Digital Auto Tracking

This feature continuously analyzes the signal and adjusts for optimum picture quality.

Manual Tracking Control

Use during Playback and Slow Motion mode to reduce picture noise. Push **VCR CH (TRACKING)** ▲/▼ buttons until the picture clears up. To return to Auto Tracking mode, push **VCR POWER** off and then on again.

V-Lock Control

In Still mode, the **VCR CH (TRACKING)** ▲/▼ buttons operate as a V-Lock control to reduce jitter. Push ▲/▼ until the picture is stabilized.

DynAmorphous™ Metal Head/

CNR (Color Noise Reduction)/ ANR (Advanced Noise Reduction)

DynAmorphous™ Metal Head increases playback and record picture quality. Color Noise Reduction reduces the color noise. Advanced Noise Reduction reduces the luminance noise.

Caution:

Please inspect your cassette tape for any loose or peeling labels as it may become jammed in your unit.

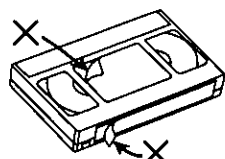

Record On a Tape



Check list before you begin.

- All connections are made. (See pages 6~9.)
- VCR is Plugged in.
- TV is turned on and set to the VCR channel (CH3 or CH4).

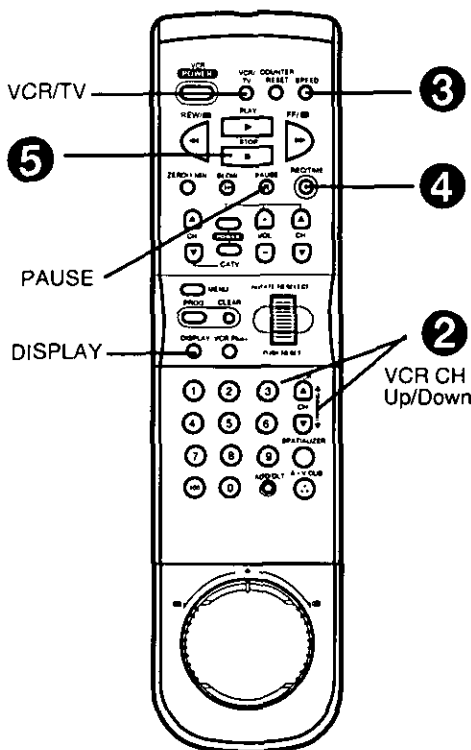
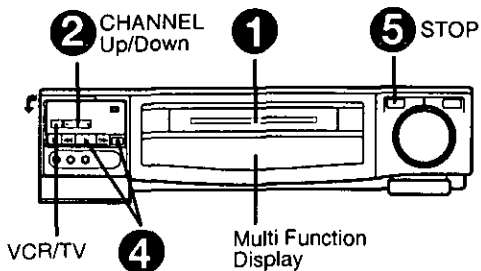

1 Insert a cassette with record tab.

- VCR power comes on automatically.
- If you are making an S-VHS recording, make sure the S-VHS Selector Switch is set to "ON".

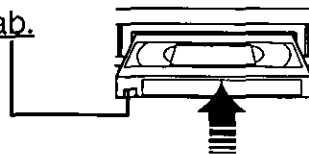

2 Push VCR CH ▲/▼ or NUMBERED keys to select a channel.

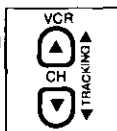

- Or, push CHANNEL ▲/▼ on the VCR.
- To record from an outside source, push VCR CH ▲/▼ to select "LINE1" or "LINE2" (see page 25).

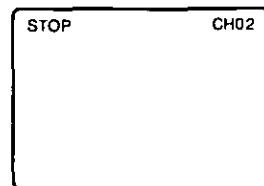

3 Push SPEED to change current recording speed.

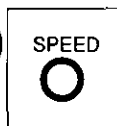

- SP = Standard Play, LP = Long Play, SLP = Super Long Play.
- Select SP or SLP when making an S-VHS recording.

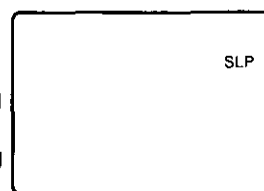

4 Push REC/TIME to start recording.

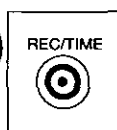

- Or, push PLAY and REC/TIME on VCR.

One Touch Timer Recording (OTR)

The VCR starts recording and turns itself off at a preset time.

Continue to push REC/TIME to set the recording length. Each push will change the stop time as shown.

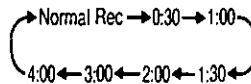

- "TIMER" lights in the Multi Function Display.

5 Push STOP to stop recording.

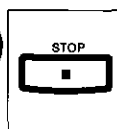

- Or, push STOP on the VCR.

Watching Another TV Program

- 1 Push VCR/TV while recording is in progress to turn off the VCR indicator in the Multi Function Display.
- 2 Use the TV channel controls to select a program. The VCR will continue to record your program while you watch any channel you choose.
 - Switch back and forth between the recording and viewing channel with the VCR/TV selector.

Selecting Channels at the VCR

- 1 Turn TV on.

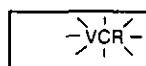

Multi Function Display

If indicator doesn't light, push VCR/TV to turn it on.

- 2 Use VCR CH ▲/▼ buttons to select channels for viewing or recording.
 - To resume TV control channel selection, push VCR/TV to turn VCR indicator off, or simply turn VCR off.



- Holding down the VCR CH ▲/▼ buttons will increase the channel search speed.
- Push PAUSE to pause a recording in progress. (After the VCR has been in Pause mode for 5 minutes, it will stop automatically to protect the tape and video head.)
- The recording time remaining appears if the DISPLAY button is pushed during OTR mode (See page 18).



Tape Operation

Your VCR is equipped with several time saving features as well as convenient automatic functions which make tape operation easier than ever.

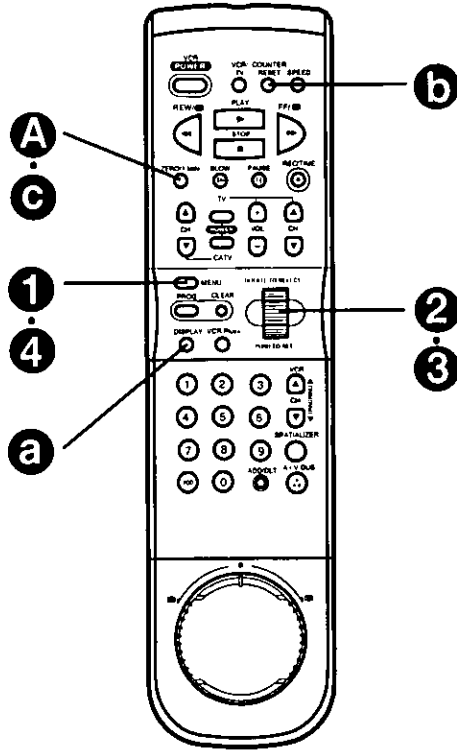

Repeat Play

You can set your VCR up to play a recording over and over.

1  Push MENU to display the menu.

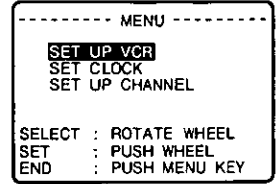

2  Rotate and push the WHEEL to select SET UP VCR.

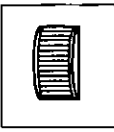
3  Rotate the WHEEL to select "REPEAT PLAY", then push to select "ON" or "OFF".

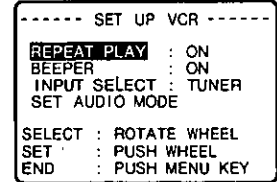

- The VCR plays to the end of a tape, or until a blank portion of 30 seconds or more is reached. (Erased portions of tape are not considered blank.) The tape is then automatically rewound and played again and again until Repeat Play is cancelled. All function buttons (REW, FF, etc.) are operational during Repeat Play.

4  Push MENU twice to leave this screen.

One Minute Skip

With this feature, you can skip over commercials recorded on a tape.

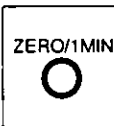
A  Push ZERO/1MIN in Play mode.

- The VCR will go into FF search mode and skip over 60 seconds of recorded time. Then, normal playback will resume.

Auto Operation Functions

Auto Playback

When a tape is inserted, the power comes on (Auto). If the record tab* is removed, playback begins (Auto).

Auto Rewind

After a tape reaches its end during playback, fast forward or manual record, the VCR will rewind and go into Stop mode.

Playback Auto Eject

After a tape without a record tab* is played to its end, the VCR will rewind and then eject the tape.

Memory Rewind Off

When the POWER button is pushed during rewind, the VCR will turn off after rewind is complete.

Eject Cassette

A cassette may be ejected with power on or off.

* For record tab information, see page 5.

Zero Search

You can reset the Time Counter to zero and then return to that point.

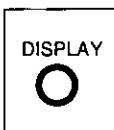
a  Push DISPLAY to display the Time Counter overlay.

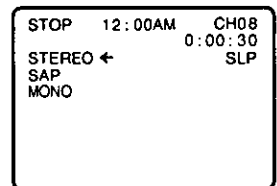

b  Push COUNTER RESET to reset the Time Counter.

- This may be done at as many places as you wish on the tape.

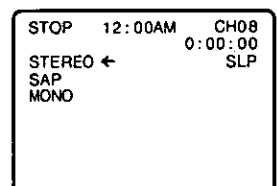

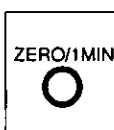
c  Push ZERO/1MIN in Stop mode.

- The VCR will go into FF or REW mode and stop at the last point the Time Counter was set to 0:00:00.

Basic Operation



Timer Recording

Your VCR can be set up to do a recording while you are away or otherwise occupied. Up to 8 programs can be placed in memory. You can choose to record one time, daily, or weekly.



Check list before you begin.

- All connections are made. (See pages 6~9.)
- TV and VCR are plugged in and turned on.
- VCR/TV selector is set to "VCR."
- Clock is set to correct time.
- Record tab in place. (See page 5.)

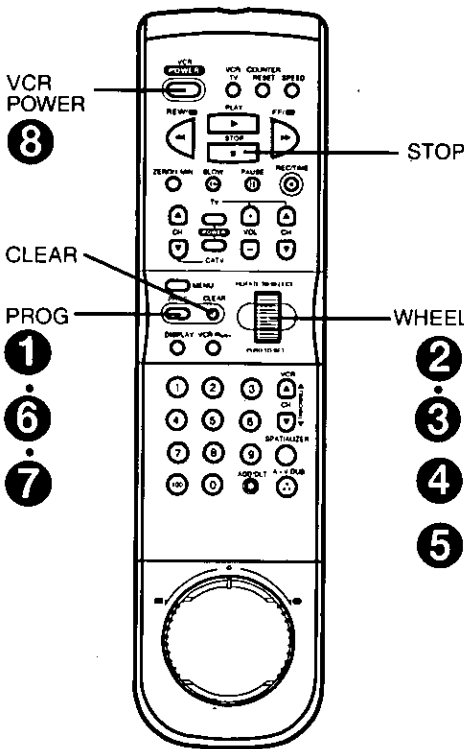
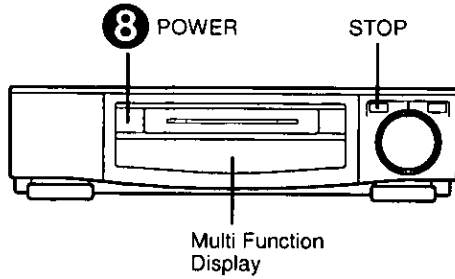

Important notes when using a DSS receiver.

- When recording programs via a DSS receiver the DSS receiver must be left on.
- When recording programs via an antenna or cable, the DSS receiver must be turned off.

1



Push PROG to display the program screen.

- If a program is already in memory, use the Wheel to select an unused program number.

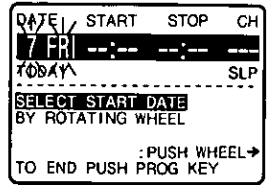

2

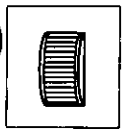

Rotate and push the WHEEL to select and set the DATE.

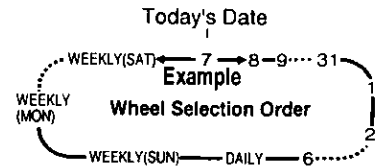

Daily and Weekly Timer Recording

If you want the program to be recorded daily (Mon thru Fri), enter DAILY in place of the DATE in step 2. If you want the recording to be on a weekly basis, enter WEEKLY MON, TUE, etc..

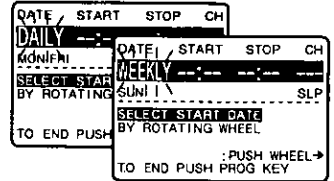

3

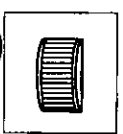

Rotate and push the WHEEL to select and set remaining items at right.

Remaining Items to be set:

- START time
- STOP time
- CH(annel) number, or LINE for outside source recording.
- Speed (SP, LP, SLP).

To Make Corrections

Repeatedly push the Wheel to move forward, or the CLEAR button to move back to the desired item.

4



Push the WHEEL when program is completed. "PROGRAM COMPLETED" will appear on-screen.

- If "PROGRAM IS INCOMPLETE" appears on-screen, check all entries and make necessary corrections.
- If you enter a channel number of 100~125, the screen at right appears a few seconds later.

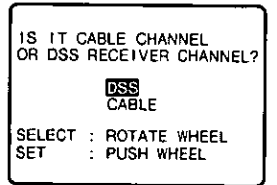

5

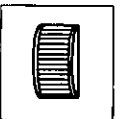

Rotate and push the WHEEL to select "DSS" or "CABLE".

6



Push PROG to end the program.

- If you want to enter more programs, select a blank program number with Wheel and repeat steps 2 and 3.

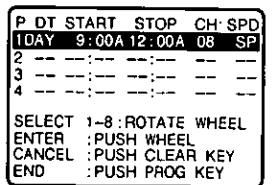

7



Push PROG to exit this mode.

8

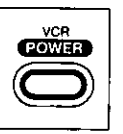

Push VCR POWER off to set the timer.

- When recording programs via a cable box, make sure the cable box is left on. If the cable box cannot be controlled with the VCR, you must manually select the desired channel.



Multi Function Display



- If a DSS channel is selected, the channel will appear as blue numbers on white background.
- If the cassette record tab is missing at the time the VCR power is turned OFF, the tape ejects and the TIMER indicator flashes in the Multi Function Display.
- If the start times of two programs overlap, the lower numbered program will have priority.
- If the start time for a timer recording comes up during a normal recording or One Touch Recording (page 20), the timer recording will not be performed.



Timer Recording Using VCR Buttons

A timer recording can be set up using the buttons on the VCR. If necessary, the clock can also be set.

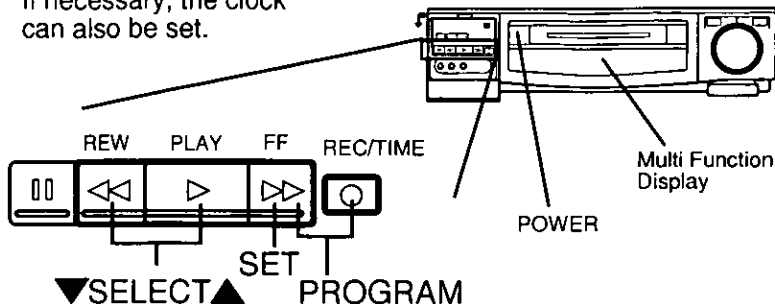

Cancel a Timer Recording: Recording is in progress

- 1 Push the VCR POWER button to release the VCR from timer mode.
- 2 Push the STOP button within 10 seconds of pushing the VCR Power button to cancel the recording. The TIMER indicator goes out in the Multi Function Display.

Replace Program Contents: Recording is not in progress

- 1 Push the PROG button to display all currently set programs.
- 2 Rotate and push the Wheel to select and enter the desired timer recording. (See page 22.)
- 3 Rotate and push the Wheel to select and enter replacement information.
- 4 Push the PROG button to exit this mode and return to the normal TV screen.

| P | DT | START | STOP | CH | SPD |
|---|----|--------|--------|-----|-----|
| 1 | | | | | |
| 2 | 8 | 10:00P | 12:00P | 125 | SLP |
| 3 | 10 | 8:00P | 9:00P | B50 | SP |
| 4 | SU | 9:00P | 10:00P | L | SLP |

SELECT 1-8: ROTATE WHEEL
 ENTER : PUSH WHEEL
 CANCEL : PUSH CLEAR KEY
 END : PUSH PROG KEY

| DATE | START | STOP | CH |
|-------|--------|--------|-----|
| 8 SAT | 10:00P | 12:00P | 125 |

SELECT START DATE
 BY ROTATING WHEEL
 ←PUSH CLEAR : PUSH WHEEL→
 TO END PUSH PROG KEY

Review or Clear Program Contents: Recording is not in progress

- 1 Push the PROG button to display all currently set programs.
- 2 Rotate the Wheel to select the desired program number.
- 3 Push the CLEAR button to clear the program.
- 4 Push the PROG button to exit this mode and return to the normal TV screen.

| P | DT | START | STOP | CH | SPD |
|---|-----|--------|--------|-----|-----|
| 1 | DAY | 9:00A | 12:00A | 08 | SP |
| 2 | 8 | 10:00P | 12:00P | 125 | SLP |
| 3 | 10 | 8:00P | 9:00P | B50 | SP |
| 4 | SU | 9:00P | 10:00P | L | SLP |

SELECT 1-8: ROTATE WHEEL
 ENTER : PUSH WHEEL
 CANCEL : PUSH CLEAR KEY
 END : PUSH PROG KEY

| P | DT | START | STOP | CH | SPD |
|---|----|--------|--------|-----|-----|
| 1 | | | | | |
| 2 | 8 | 10:00P | 12:00P | 125 | SLP |
| 3 | 10 | 8:00P | 9:00P | B50 | SP |
| 4 | SU | 9:00P | 10:00P | L | SLP |

SELECT 1-8: ROTATE WHEEL
 ENTER : PUSH WHEEL
 END : PUSH PROG KEY

1 Hold down REC/TIME.

| DATE | START | STOP | CH |
|-------|-------|-------|-----|
| 7 FRI | --:-- | --:-- | -- |
| TODAY | | | SLP |

SELECT START DATE
 BY SELECT ▲/▼ KEY
 NEXT, PUSH SET KEY OR
 TO END PUSH PROG KEY

and Push FF to enter the program mode.

| SET CLOCK | DST: ON |
|-----------|---------|
| --:-- | |

SELECT MONTH
 BY SELECT ▲/▼ KEY
 NEXT, PUSH SET KEY OR
 TO END PUSH PROG KEY

- If the clock is not set, pushing these buttons will display the SET CLOCK screen. In this case, proceed with steps 2 and 3 to set the clock and then steps 2~6 to set a timer recording.
- Once the VCR is in the Program mode, the PLAY, REC, FF, and REW buttons on the VCR operate only as specified above.

2 or Push REW or PLAY to make your selection.
(for down) (for up)

3 Push FF to set and move on to the next item.
• Push SET (FF) repeatedly to move to a particular item for setting or correction.

- Items to be Set:**
- recording DATE
 - START time
 - STOP time
 - CH(annel), or LINE
 - SPEED (SP, LP, SLP)

When the program is completed...

4 and Push REC/TIME and FF to display program contents.
(at the same time)

To set the next program, repeat steps 2, 3, and 4 before continuing with step 5.

5 and Push REC/TIME and FF to exit this mode.
(at the same time)

6 Push POWER off to set the timer. Multi Function Display

- It is not possible to clear a timer program using the VCR buttons. Please use the Remote Control.
- When recording programs via a cable box, make sure the cable box is left on. If the Cable box cannot be controlled with the VCR, you must manually select the desired channel.

S VHS Super (S) VHS System

S-VHS tape playback is superior to VHS, even when using a conventional TV. And, your S-VHS VCR can also play back VHS format tapes.

S-VHS and VHS Tapes

Both Super-VHS and VHS recordings can be made on an S-VHS tape. Tapes recorded in VHS may be played back on either an S-VHS or VHS type VCR. Tapes recorded in S-VHS cannot be played back on a conventional VHS VCR.

- When a VHS recorded tape is played back on your S-VHS VCR, the VHS mode is automatically selected.
- Playback and Recording operations are described on pages 19 and 20.
- When making an S-VHS recording, SP or SLP tape speed must be used.

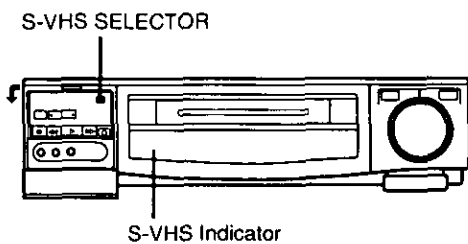
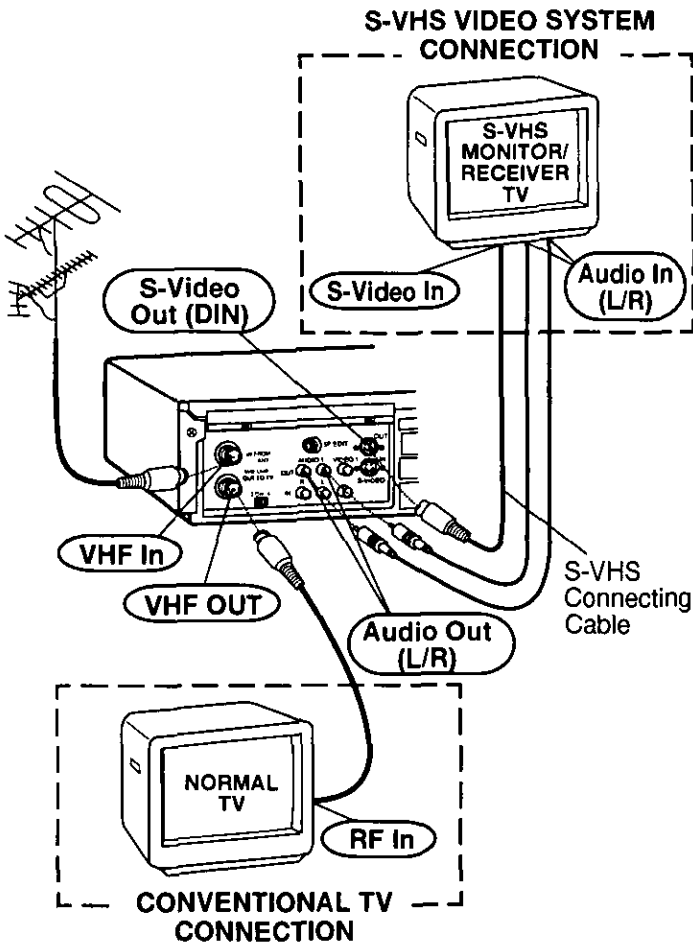

Compatibility

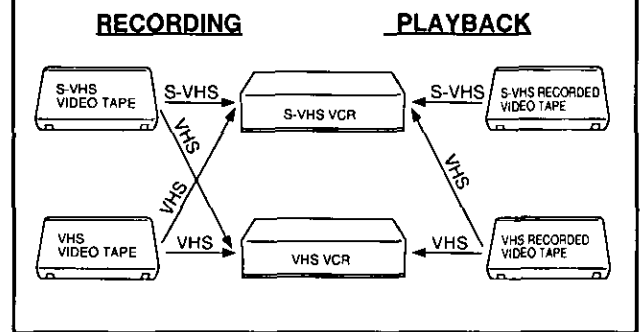

When the S-VHS Selector switch is set to on, the recording mode is automatically set according to the type of cassette tape used, S-VHS or VHS. When the S-VHS Selector switch is set to off, recording is done in the normal VHS mode, regardless of the type of cassette tape inserted. Use the off position when recording on an S-VHS tape in VHS mode to be played back on a VHS VCR.

| S-VHS SELECTOR S-VHS AUTO OFF <input type="checkbox"/> ON <input type="checkbox"/> | Cassette Tape | |
|--|-----------------|---------------|
| | SUPER VHS | VHS |
| ON | S-VHS RECORDING | VHS RECORDING |
| OFF | VHS RECORDING | VHS RECORDING |

NOTES

- A conventional VCR will not be able to play back your S-VHS recordings. To make recordings that are compatible with conventional VHS VCR's, use your S-VHS VCR with the S-VHS Selector switch set to "OFF".
- The "S-VHS" Indicator lights up when the power comes on, when using an S-VHS tape to make an S-VHS recording and during S-VHS tape playback.



Copying Your Tapes (Dubbing)

Connections you'll need to make.

- on the editing S-VHS VCR, set the S-VHS selector to on. (Choose front or rear connection.)

TV for Monitoring

Recording (Editing) VCR

Playing (Source) VCR

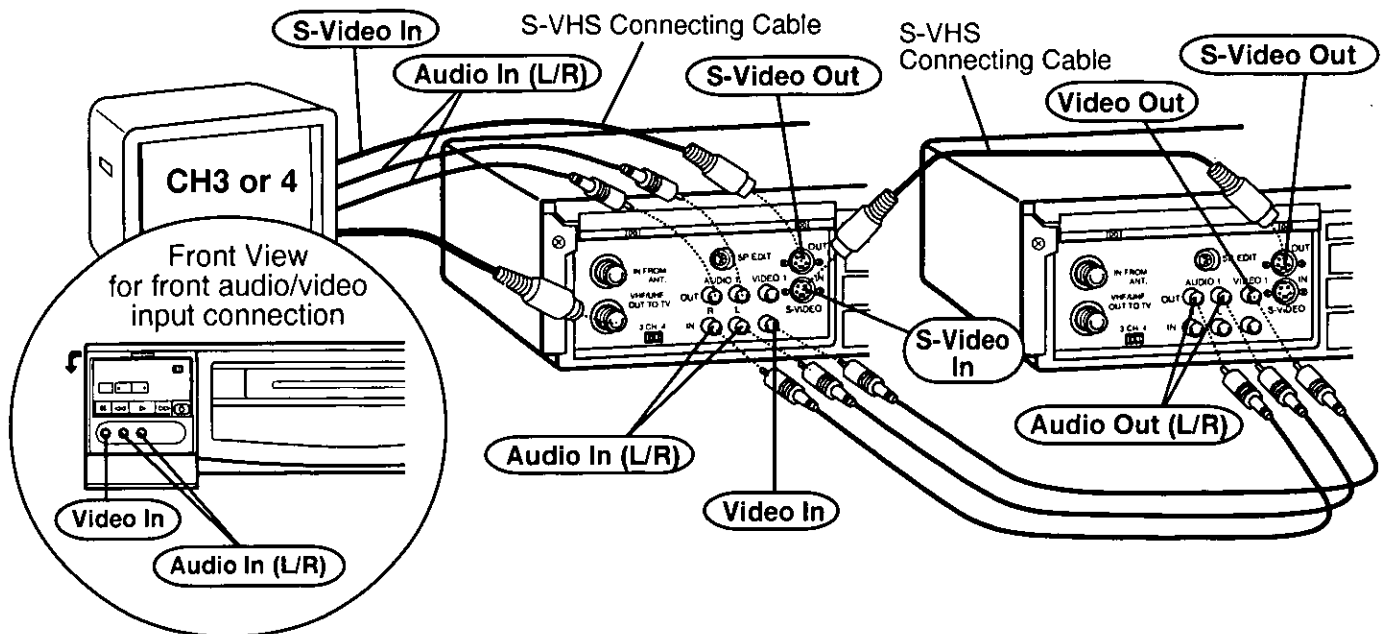

- 1 Insert a pre-recorded tape into the Playing (Source) VCR.

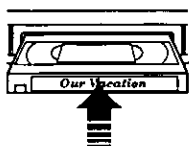

- 2 Insert a blank tape with record tab into the Recording (Editing) VCR.

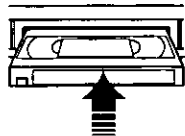

- 3 Select Input "LINE" on the Recording (Editing) VCR. (See "Selecting the Input Mode" at right.)

- 4 Push PLAY on Playing VCR. Push PAUSE at the point you want to start copying.

- 5 Push REC and PLAY at the same time on Recording VCR. Push PAUSE immediately.

- 6 Push PAUSE on both VCRs (at the same time), to begin copying.

Edit Out Unwanted Parts of the original recording by using the PAUSE button (on the Recording unit) while copying is in progress.

- 7 Push STOP on both VCRs to stop copying.

To Monitor the Re-Recording

- 1 Turn the TV on and select its VCR channel (CH3 or CH4) on the Recording VCR.
- 2 Set the VCR/TV selector on the Recording VCR to the "VCR" position.

Selecting the Input Mode

- 1 Push MENU to display the menu.
- 2 Rotate and push the Wheel to select SET UP VCR.
- 3 Rotate the Wheel to select "INPUT SELECT", and then push to choose TUNER or LINE (LINE1 or LINE2).

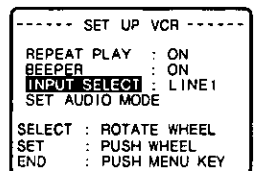
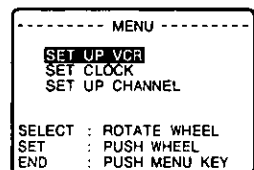

- LINE1: For rear audio/video connection.
- LINE2: For front audio/video connection.
- You can also select "LINE1" or "LINE2" using the VCR CH ▲/▼ buttons. The numbers will change in the order shown.

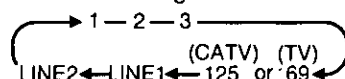

- When LINE is selected, "L1" or "L2" is displayed in the Multi Function Display for about 4 seconds.

Caution:

Unauthorized exchanging and/or copying of copyrighted recordings may be copyright infringement.

More You Can Do

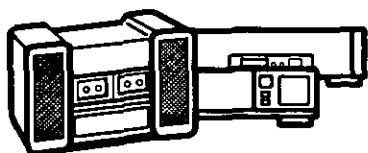

Dubbing Over Your Recording

Because your VCR uses Flying Erase Head technology, you can dub over the original video, audio or both video and audio portion of your recording with exceptional quality.



Check list before you begin

- Connections below are complete.
- The master tape is inserted into the playing VCR or camcorder and the tape (with record tab) to be dubbed over is inserted into the recording VCR.

Connections

TV for Monitoring

Recording (Editing) VCR

Playing (Source) VCR

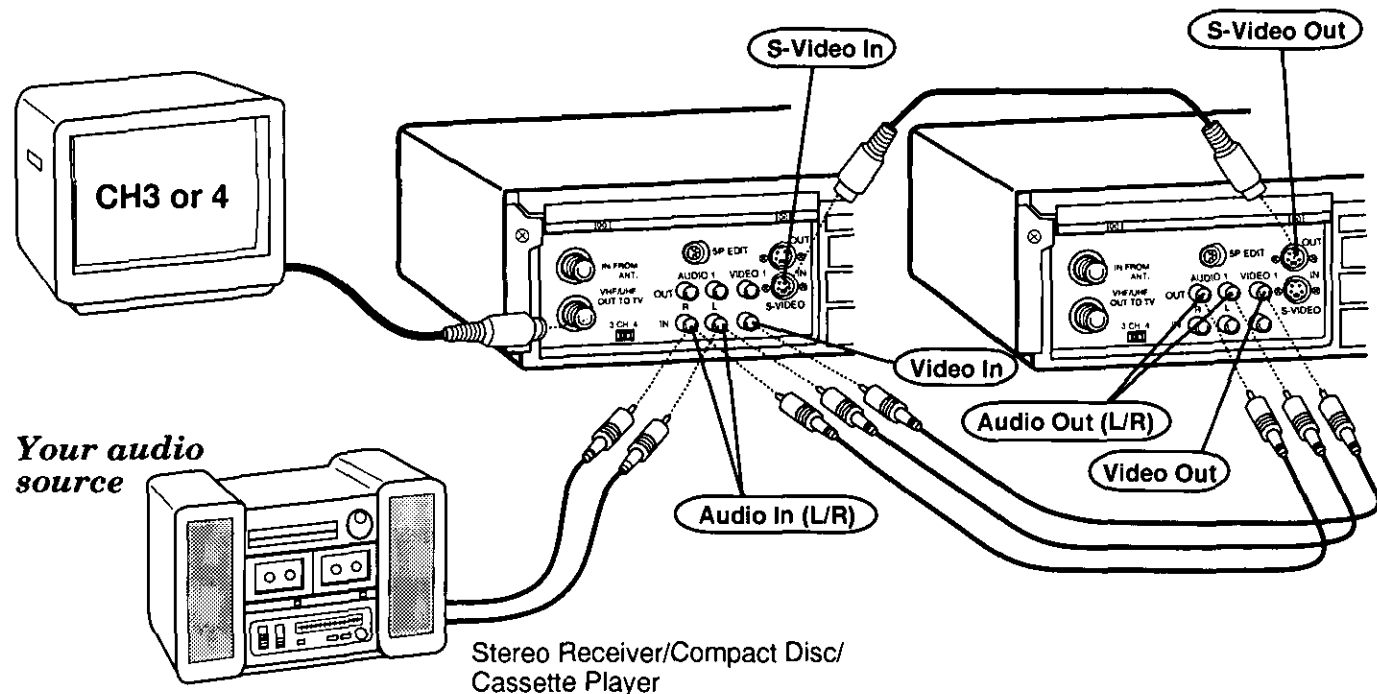

Your audio source

Stereo Receiver/Compact Disc/Cassette Player

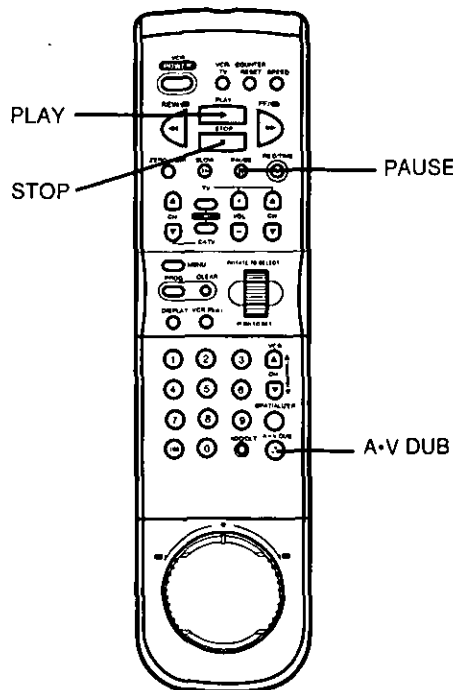
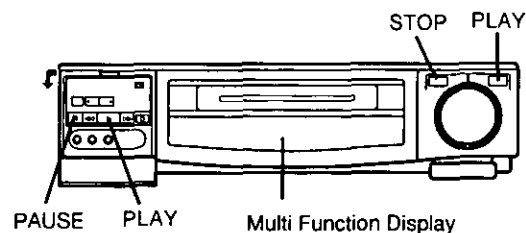

Dubbing from Your Audio

Make sure audio connections are complete.

- 1** Select Input "LINE1" or "LINE2".
 - See the "Selecting the Input Mode" section on page 25.

- 2** Push **PLAY**, and then push **PAUSE** where you want the dubbing to begin.
 - The VCR and your audio source should now be in Still mode.

- 3** Push **A-V DUB**.
 - The "A.DUB" indicator appears in the Multi Function Display.

- 4** Push **PAUSE** on the VCR and at the same time, start the audio source playback.

- 5** Push **STOP** on the VCR and your audio source to stop the audio dubbing.

• An audio dub will only be performed on the normal (mono) track. Hi-Fi audio sound will not be affected.

Dubbing over the Video

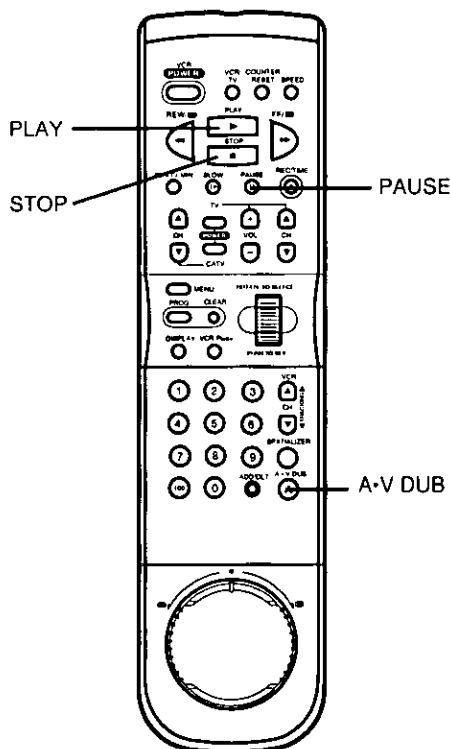
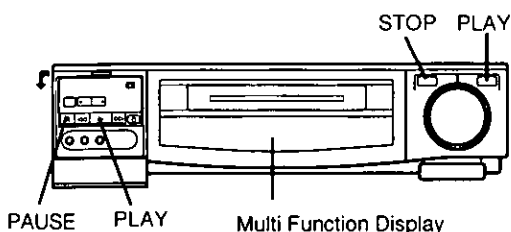

- 1 Select Input "LINE1" or "LINE2".
 - See the "Selecting the Input Mode" section on page 25.

- 2 Push **PLAY**, and then push **PAUSE** where you want the dubbing to begin. Do this first on the playing and then the recording VCR.
 - Both VCRs should now be in Still mode.

- 3 Push **A·V DUB** twice on the recording VCR.
 - The "V.DUB" indicator appears in the Multi Function Display.

- 4 Push **PAUSE** on both VCRs simultaneously.

- 5 Push **STOP** on both VCRs to stop the dubbing.

- Hi-Fi sound will be erased while the normal (mono) sound remains unchanged.

Dubbing Over Audio and Video

Make sure both Audio and Video connections are made.

- 1 Select Input "LINE1" or "LINE2".
 - See the "Selecting the Input Mode" section on page 25.

- 2 Push **PLAY**, and then push **PAUSE** where you want the dubbing to begin.
 - Both VCRs and your audio source should now be in Still mode.

- 3 Push **A·V DUB** three times on the recording VCR.
 - The "A.DUB" and "V.DUB" indicators appear in the Multi Function Display.

- 4 Push **PAUSE** on both VCRs and at the same time, start the audio source playback.

- 5 Push **STOP** on both VCRs and your audio source to stop the Audio/Video dubbing.

- Both Hi-Fi and normal (mono) audio sound will be replaced by the new recording.



- Do not use the VCR Plus+ feature during Audio, Video, or Audio/Video dubbing.

- If both units are not S-VHS, connect the VIDEO OUT of the playing VCR to the VIDEO IN of the recording VCR.



Using the 5 Pin Editing Controller

For greater flexibility and control over the editing process, this VCR is equipped with a 5 pin editing terminal for connection to an Editing Controller, or to a Personal Computer via a Computer Interface. The simplified diagrams below give you an idea of how your VCRs can be hooked up to meet your editing needs. Detailed instructions on connection and operation can be found in your Editing Controller or PC Interface Product.

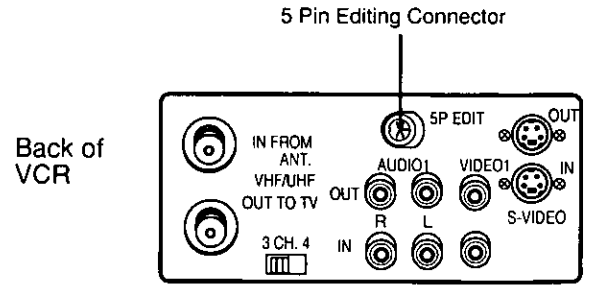

Editing Controller Hook-up

(Both VCRs must have a 5 pin editing terminal.)

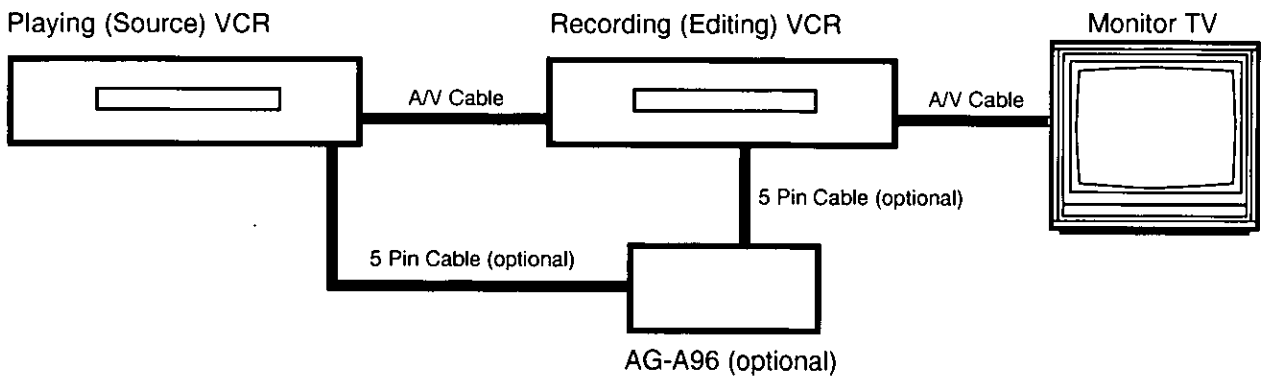

Personal Computer Hook-up

(A V-STATION must be used.)

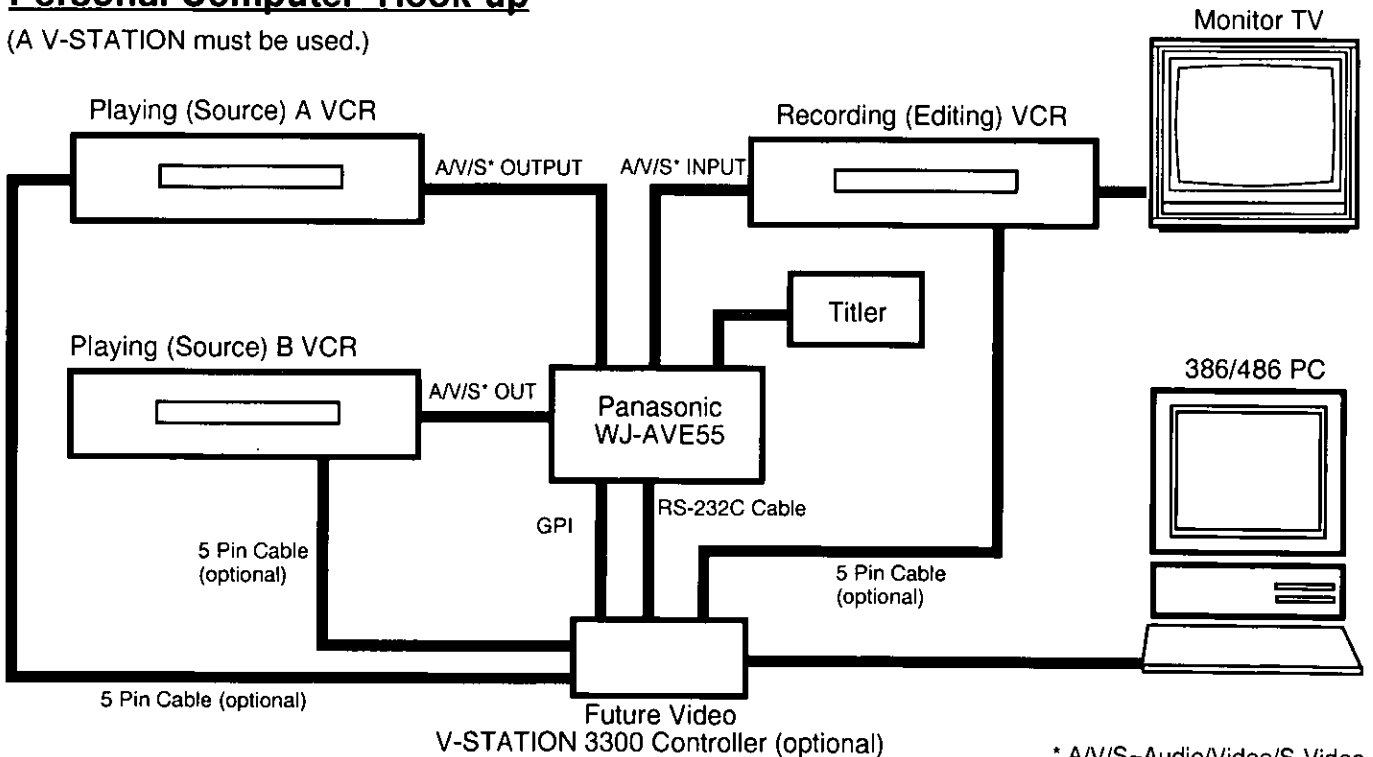

* AV/S=Audio/Video/S-Video

Product Information for Edit Controllers and 5-Pin VCRs/Camcorders.

The following chart lists commands available with the Panasonic Edit Controller (AG-A96).

| COMMAND | |
|-----------------------|-----|
| STOP | YES |
| EJECT | YES |
| REWIND/LOCKING REVIEW | YES |
| FF/LOCKING CUE | YES |
| REVIEW | YES |
| CUE | YES |
| STILL/PAUSE | YES |
| RECORD | YES |
| SLOW SPEED UP | YES |
| SLOW SPEED DOWN | YES |
| ASSEMBLE INSERT | YES |
| ASSEMBLE RECORD | YES |
| ASSEMBLE PLAY | YES |
| POWER ON/OFF | YES |
| COUNTER RESET | YES |
| ASSEMBLE A-DUB | YES |
| ASSEMBLE A/V INSERT | YES |
| REHEARSAL A-DUB | YES |
| REHEARSAL A/V INSERT | YES |
| REHEARSAL INSERT | YES |
| REHEARSAL RECORD | YES |
| FRAME REQUEST | YES |
| NOP (CONNECT) | YES |
| NOP (CONNECT) | YES |
| PLAY | YES |
| REVERSE PLAY | YES |
| FRAME ADVANCE | YES |
| FRAME REVERSE 1/60 | YES |
| FORWARD SLOW 1/9 | YES |

JOG SHUTTLE CONTROL

| COMMAND | |
|-----------------------|-----|
| SHUTTLE ON STILL | YES |
| REVERSE SLOW 1/5 | YES |
| FORWARD SLOW 1/5 | YES |
| REVERSE PLAY | YES |
| FORWARD PLAY | YES |
| REVERSE SLOW SPEED 5X | YES |
| CUE 5X | YES |
| REVERSE HIGH SPEED 9X | YES |
| CUE 9X | YES |
| REVERSE SLOW 1/59 | YES |
| FORWARD SLOW 1/59 | YES |
| REVERSE SLOW 1/9 | YES |
| FORWARD SLOW 1/9 | YES |
| JOG ON/OFF | YES |



- Editing may not be performed correctly if more than 10 hours have lapsed on the Time Counter. If necessary reset the Time Counter to 0:00:00 (see page 21) before starting the edit.
- When the VCR is connected to an edit controller, buttons on the VCR unit and on the remote control may not function properly during the dubbing.

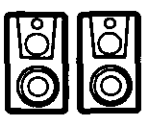

MTS Broadcast/ VHS Hi-Fi Stereo System



Check list before you begin

- The VCR is connected to a stereo TV, or a mono TV and stereo amp or receiver with speakers.
- The VCR and other components are plugged in and turned on.

Connections to Make

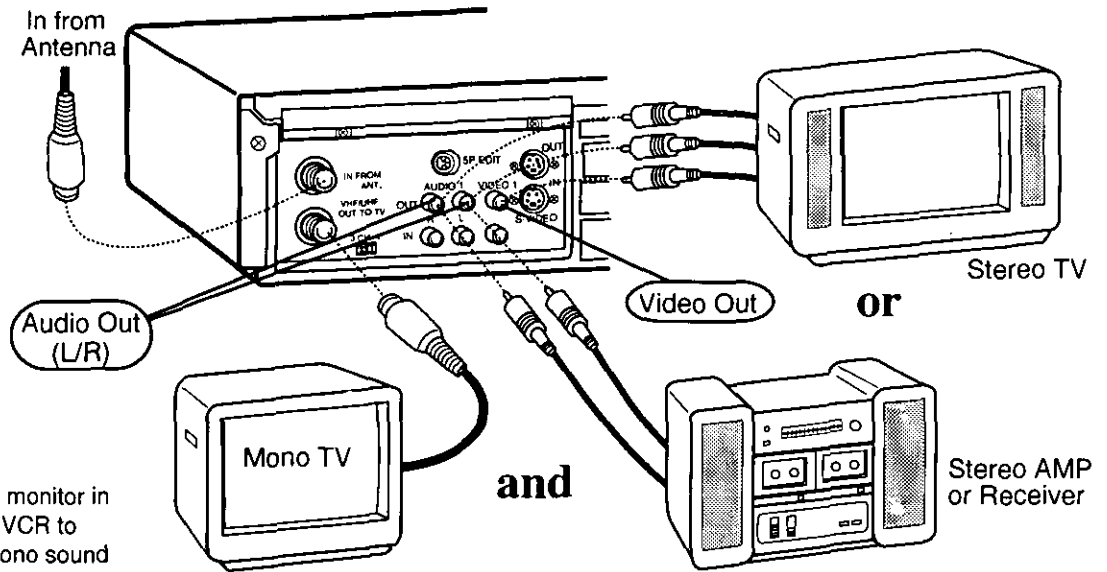

When recording, you may monitor in stereo, by connecting the VCR to either a stereo TV, or a mono sound TV with stereo amp and speakers.



Multi Function Display

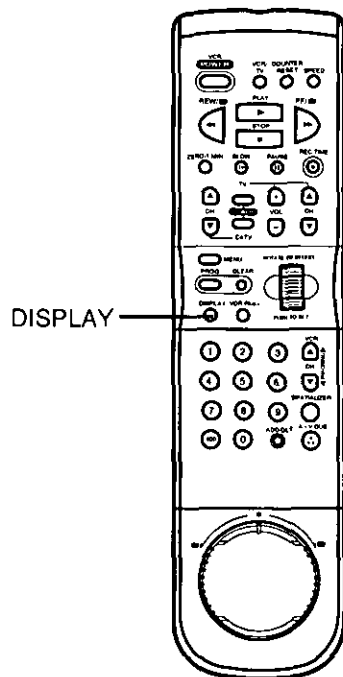

Receivable Broadcast Types

The following are possible broadcast types with their accompanying on-screen displays. The signal(s) not being received is enclosed in parenthesis. The currently selected audio mode is indicated with an arrow. To change the audio mode for listening to, or recording these broadcasts, follow the steps on page 31.

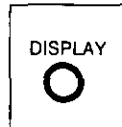

Push DISPLAY to display the broadcast signal currently being received on-screen.

MTS Stereo and SAP broadcast

Multi-channel Television Sound Stereo (main language) and Second Audio Program (second language) broadcasts are being received simultaneously. The "STEREO" and "SAP" indicators light in the Multi Function Display. Select the STEREO or SAP audio mode as desired.

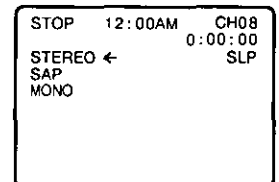

MTS Stereo broadcast

Multi-channel Television Sound Stereo broadcast is being received. The "STEREO" indicator lights in the Multi Function Display.

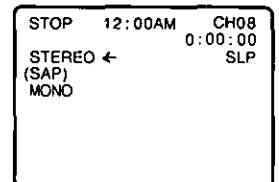

SAP broadcast

Second Audio Program (second language) broadcast is being received. The "SAP" indicator lights in the Multi Function Display. Select SAP audio mode for the second language.

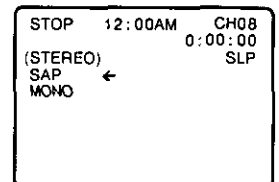

MONO broadcast

Normal monaural sound broadcast is being received.

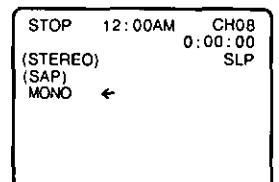

Equipped with **dbx**[®] -TV Noise Reduction for true MTS reproduction. **dbx**[®] -TV Noise Reduction is required for good stereo separation and audio fidelity. **dbx**[®] is a registered trademark, and is licensed by **dbx**[®] Technology Licensing.

- If a stereo broadcast is weak and the display flickers, you may want to select the MONO audio mode for better results.

- When recording, the currently selected broadcast sound is always recorded on the left and right Hi-Fi tracks as well as the normal monaural track. This means your tapes can be played back on Hi-Fi as well as non-Hi-Fi VCRs.

With the proper audio mode setting, your VCR can:

- 1) record and playback an MTS stereo broadcast (main language) in stereo Hi-Fi.
- 2) record and playback a monaural broadcast (main language) or Second Audio Program (second language) on the Hi-Fi tracks for better quality monaural sound.
- 3) playback non Hi-Fi tapes in monaural.

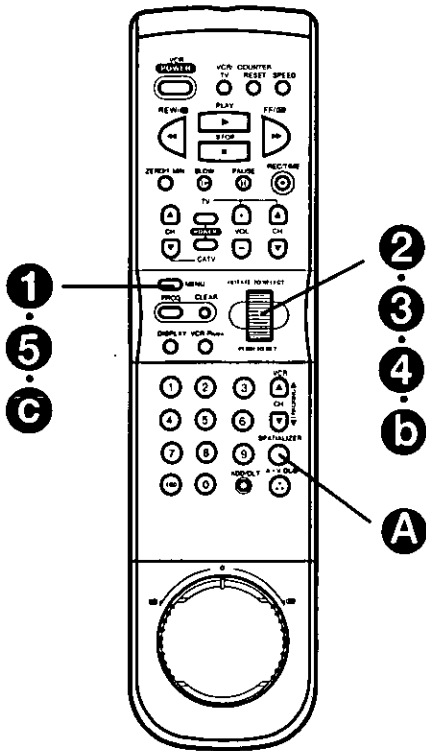

Selecting the Audio Mode for Recording

Select the type of broadcast and sound track you wish to record.



Push MENU to display the menu.

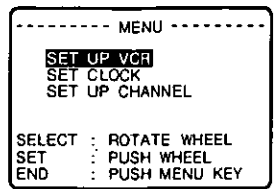

Rotate and push the WHEEL to select SET UP VCR.

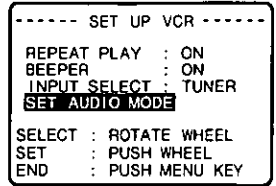

Rotate and push the WHEEL to select SET AUDIO MODE.

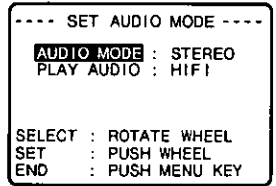

Rotate the WHEEL to select AUDIO MODE, and then push to select the desired audio mode (STEREO/SAP/MONO).

• Please refer to "Receivable Broadcast Types" section on previous page.



Push MENU three times to exit this mode.



Do a recording. See the "Record On a Tape" section on page 20.

Selecting the Audio Mode for Playback

Select the type of sound track you desire for playback.



Do steps 1, 2, and 3 above.

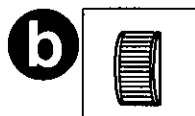
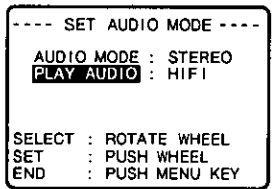

Rotate the WHEEL to select PLAY AUDIO, and then push to select the desired audio mode (HIFI/NORMAL).

• Please select HIFI to listen to your stereo recordings with stereo sound or MONO for monaural sound.



Push MENU three times to exit this mode.



Playback the tape. See the "Playback a Tape" section on page 19.

NOTES

- When purchasing or renting prerecorded tapes, remember that only those recorded in Hi-Fi stereo will play back with true stereo sound. Standard stereo tapes will play back with monaural sound.
- In order to listen to Hi-Fi stereo playback, the VCR AUDIO (L/R) jacks must be connected to a stereo TV or stereo amp and speakers. (See previous page.)
- When adjusting the tracking during playback, the Hi-Fi audio sound may revert to normal audio sound. This is normal.
- There may be a difference in audio level between Hi-Fi and normal audio playback.
- If you select "HIFI", the Hi-Fi indicator lights in the Multi Function Display.
- Rec Level Meter will show the audio level during recording or playback.

Spatializer Feature

This feature allows you to enhance the stereo sound so that it seems to completely surround you. Spatializer indicator lights in the VCR front panel when set to "HIGH" or "LOW". Your VCR needs to be hooked up to a stereo TV or stereo amp/receiver with speakers (see page 30). For playback, tapes must be recorded in Hi-Fi stereo. For TV viewing, programs must be broadcast in stereo.

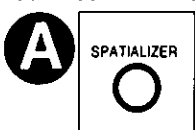

Push SPATIALIZER repeatedly to choose the desired setting.

• Each push will change the display in the order shown.

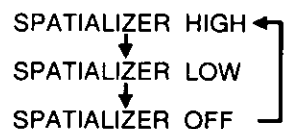

Portions of this product manufactured under a licence from Desper Products, Inc. SPATIALIZER, and the circle-in-square device are trademarks owned by Desper Products, Inc.

More You Can Do

VCR Plus+ programming allows you to set most items of a timer recording by simply entering a special code found in *TV GUIDE* magazine as well as the TV listings in selected newspapers. In order for the VCR to read this special code, some set up is required. A Guide (VCR Plus+) channel number is assigned to each local broadcast and cable station. Because this number sometimes differs from the channel your TV receives the station on, it is necessary to program the VCR with local channel information.

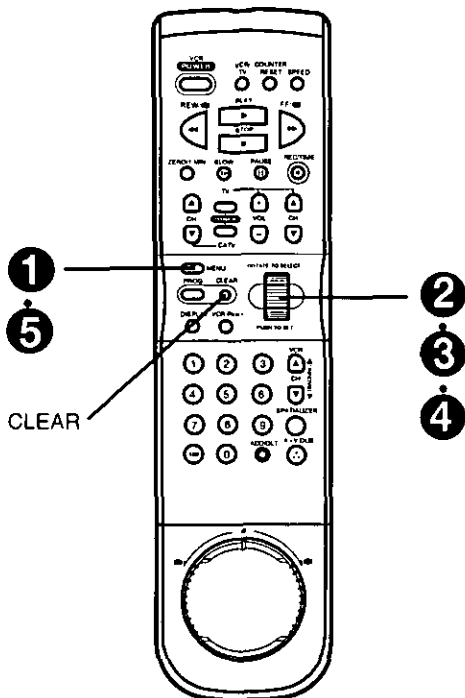

VCR Plus+ Channel Set Up (Connection Method 2 on page 12)

1 Push **MENU** to display the menu.

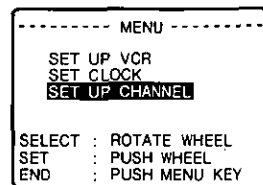

2 Rotate and push the **WHEEL** to select **SET UP CHANNEL**.

3 Rotate and push the **WHEEL** to select **VCR Plus+ CH SET UP**.

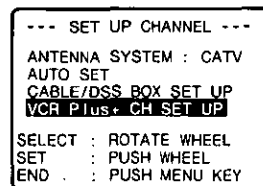

IMPORTANT NOTE:

For this step, use the list you prepared. You may leave lines blank if, you don't receive that station, or the **GUIDE CH** number and the **CATV (or TV) CH** numbers are the same.

4 Push the **WHEEL** to move the shaded area on the right side.

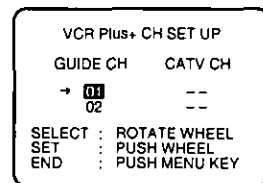

Then, rotate the **Wheel** to change **CATV** or **TV CH** number.

Next, push the **Wheel** to enter **CATV** or **TV CH** number.

Now, rotate the **Wheel** to continue. Repeat this operation until the list is complete.

To Make Corrections

Rotate and push the **Wheel** to select the incorrect **CATV** or **TV CH** number. Then, push **CLEAR** to delete the numbers. Now, use the **Wheel** to re-enter the channel.

5 Push **MENU** twice to exit the **VCR Plus+ CH SET UP** mode.

Channel Set Up Preparations

NOTE: Complete the steps on this page if you are using Connection Method 2 on page 12 for VCR hookup.

Prepare a list like the example below.

This list will help you smoothly enter the information needed in step 4 at right.

You will need the following to complete the list:

- A line up of normal and/or cable stations you receive along with the channel numbers your TV receives them on. A cable channel line-up chart is supplied by your cable company.
- A list of Guide (VCR Plus+) channel numbers assigned to the stations you receive. This list is available in *TV Guide* and the TV listings found in selected newspapers.

- 1 Make a chart with 3 columns like the example below. In the left column, fill in the name or call letters of the stations you receive.
- 2 In the middle column, fill in each station's assigned Guide (VCR Plus+) number found in *TV Guide*, newspapers, etc.
- 3 In the right column, fill in the channel number that your TV receives the station on from your channel line-up.

EXAMPLE ONLY

| Broadcast or Cable Station Name | Assigned Guide (VCR Plus+) channel no. | Channel no. your TV receives the station on |
|---------------------------------|--|---|
| HBO | 33 | 15 |
| Nickelodeon | 38 | 20 |
| CBS | 04 | 04 |
| FOX | 11 | |



- Make your entries within 60 seconds or the VCR will leave this mode.
- Once local channels have been programmed, they will stay in memory, even in the case of a power failure.

VCR Plus+C³ and PlusCode are trademarks of Gemstar Development Corporation. The VCR Plus+ system is manufactured under license from Gemstar Development Corporation.

Check list before you begin.

- The clock is set.
- One Time VCR Setup is complete.
(See pages 12~16.)
- VCR Plus+ Set Up is complete. (See page 32.)

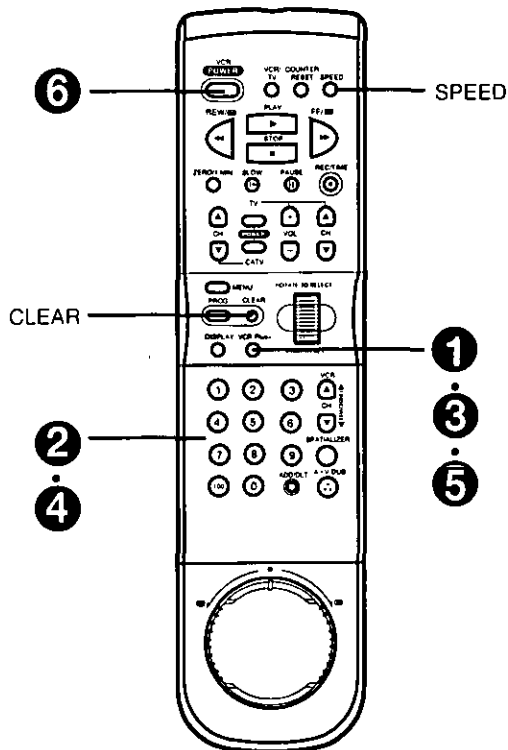
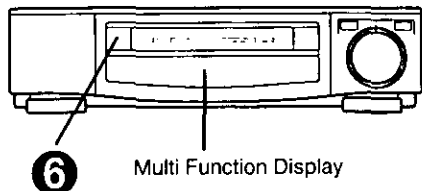

Use normal Timer Recording steps if:

- the PlusCode for a program is not listed.
- you anticipate the program, such as a sporting event, to run over the scheduled stop time.

See page 23 to:

- Cancel a timer recording in progress
- Replace program contents
- Review or Clear program contents once set

Important notes when using a DSS receiver.

- When recording programs via a DSS receiver the DSS receiver must be left on.
- When recording programs via an antenna or cable, the DSS receiver must be turned off.

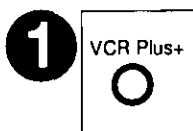

Push VCR Plus+ to display the VCR Plus+ screen.

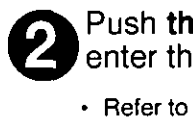
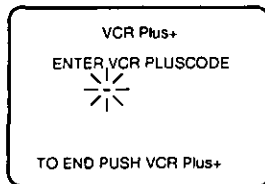

Push the Numbered Keys to enter the PlusCode number.

- Refer to your local TV listings.

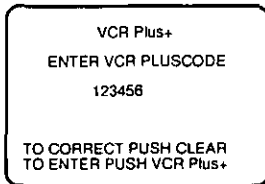

To make corrections

Push the CLEAR button repeatedly to delete the PlusCode number. Then, enter the correct number.

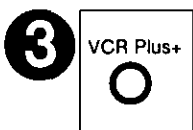

Push VCR Plus+ to lock in your program.

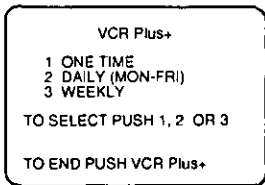

Push 1, 2 or 3 Key to select the program type.

To change the recording speed:

Push the SPEED button for SP, LP or SLP.

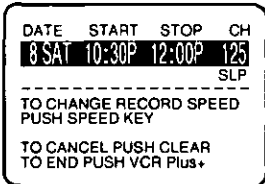

To cancel program contents:

Push the CLEAR button.

- If you use Connection Method 1 on page 12, the channel shown in the on-screen display in this step will always be the cable box output channel number.

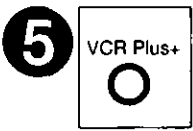

Push VCR Plus+ to complete the program.

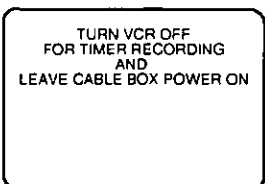

- When recording programs via a cable box, make sure the cable box is left on. If the cable box can not be controlled with the VCR, you must manually select the desired channel.
- This display may differ depending on your cable box hook-up.

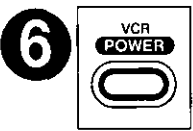

Push VCR POWER off to set the timer.

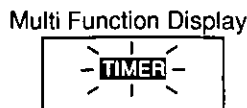

- VCR PlusCodes can not be used to program the VCR to record DSS channels.
- Avoid overlapping program times.
- An on-screen display will indicate if an invalid PlusCode number has been entered.
- An on-screen display will indicate when all timer programs are full.

More You Can Do



Special VCR and Remote Features



Check list before you begin.

- All connections are made. (See pages 6~9.)
- VCR is Plugged in.
- TV is turned on and set to the VCR channel (CH3 or CH4).

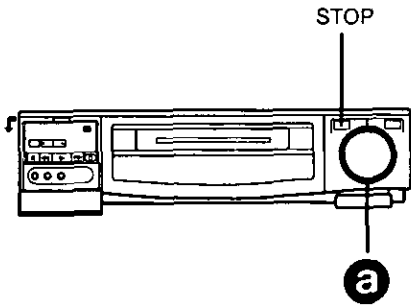

VCR Lock Feature

When activated, this feature prohibits all operations except for timer recording, and tape eject. This is useful to prevent misoperation and protect your VCR from curious children.

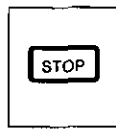

Hold down STOP on the VCR for 7 seconds during Stop, or Power OFF mode.

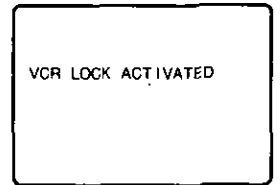

To Cancel the VCR Lock feature,

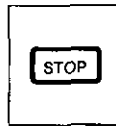

Hold down STOP on the VCR for 7 seconds again during Stop, or Power OFF mode.

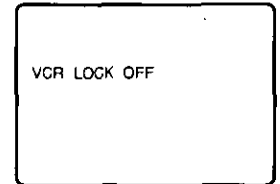

- VCR Lock mode is cancelled automatically after 24 hours when the clock is set.
- VCR Lock feature is not available if the cassette is inserted.

Warning Beeper Feature

When you select BEEPER ON as described below, a short warning will sound each time an invalid entry or operation is made and a timer program is set.

1



Push MENU to display the menu.

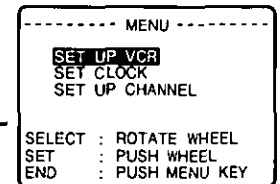

2

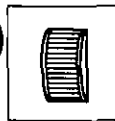

Rotate and push the WHEEL to select "SET UP VCR".

3

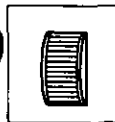

Rotate the WHEEL to select "BEEPER", then push to select "ON" or "OFF".

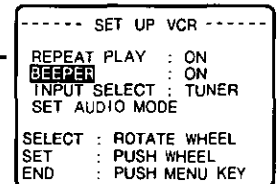

4



Push MENU twice to exit this screen.

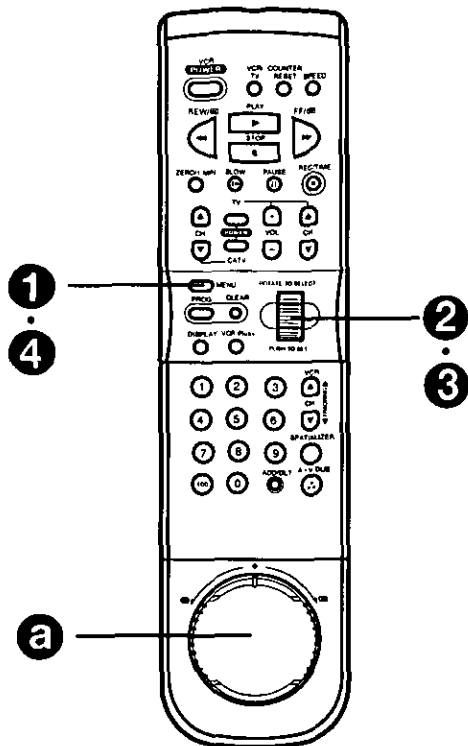

Shuttle Variable Speed Search

The SHUTTLE Ring allows you to smoothly control the tape speed during special effects playback in both forward or reverse.

a

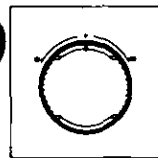

Turn SHUTTLE Ring on the VCR or remote while in Play or Still mode to place the VCR in Shuttle mode and start a forward or reverse search.

- The Shuttle indicator lights.
- The more you turn the Ring, the faster the search speed will be.

b

Push a function button such as: PLAY, STOP, etc. on the VCR or remote to release the Shuttle mode.

- The VCR performs the function of the button pushed.
- The Shuttle indicator goes out.



- When the SHUTTLE Ring on the VCR is turned more than half way in Stop mode, normal Fast Forward or Rewind will begin.
- Some noise bars are normal during Shuttle operation.
- After 3 minutes in Still or Slow, the VCR will go into Stop mode.
- When the SHUTTLE Ring is released, the VCR goes into Still mode.

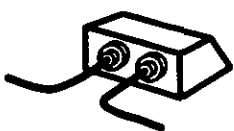

Multi-Brand Control Feature

The Remote Control may be set up to control some of the functions on your TV or Cable Box.

TV Brand Code Numbers

| | |
|------------|------------|
| Panasonic | 01, 02 |
| Quasar | 01, 02 |
| RCA | 03 |
| GE | 03 |
| Zenith | 04 |
| Magnavox | 05 |
| Sylvania | 05 |
| Sharp | 06, 07 |
| Sony | 08 |
| Toshiba | 09 |
| Sanyo | 10 |
| Fisher | 10 |
| JVC | 11 |
| Hitachi | 12 |
| Mitsubishi | 13 |
| Samsung | 14 |
| Gold Star | 15, 16, 17 |

Cable Box Brand Code Numbers

| | |
|---------------------|--|
| Archer | 01; 29, 44, 88, 91 |
| Cableview | 4, 30, 42, 44, 52, 63, 85, 88 |
| Citizen | 4, 30, 42, 44, 52, 63, 85, 88 |
| Curtis | 08, 09, 56, 61, 87, 90 |
| Diamond | 01, 29, 44, 88, 91 |
| Drake | 37 |
| Eagle | 13, 20, 22, 26, 40, 58, 62, 98 |
| Eastern | 28 |
| GC Brand | 4, 30, 42, 44, 52, 63, 85, 88 |
| Gemini | 04, 85 |
| General Electric | 57 |
| General Instruments | 01, 02, 03, 04, 34, 55, 83, 85, 91, 93, 95 |
| Hamlin | 14, 15, 28, 41, 97 |
| Hitachi | 31, 79 |
| Jerrold | 01, 02, 03, 04, 34, 55, 83, 85, 91, 93, 95 |
| Macom | 31, 79 |
| Magnavox | 25, 26 |
| Matsushita | 16, 17 |
| Movietime | 32, 38, 40 |
| Movietime | 29, 32, 39, 42, 44, 88 |
| NSC | 32, 38, 40 |
| Oak | 46 |
| Panasonic | 16, 17 |
| Philips | 13, 20, 23, 24, 96 |
| Pioneer | 05, 06, 78 |
| Pulser | 4, 30, 42, 44, 52, 63, 85, 88 |
| RCA | 16, 17 |
| Realistic | 44, 88 |
| Regal | 14, 41 |
| Regency | 28 |
| Rembrandt | 29, 32, 39, 42, 44, 88 |
| Samsung | 32, 40, 42, 78, 94 |
| Scientific Atlanta | 08, 09, 56, 61, 87, 90 |
| Sheritech | 27 |
| SL Marx | 32, 40, 42, 78, 94 |
| Sprucer | 16, 17 |
| Stargate | 32, 40, 42, 78, 94 |
| Stargate | 4, 30, 42, 44, 52, 63, 85, 88 |
| Sylvania | 19 |
| Telection | 77, 92 |
| Television | 32, 40, 42, 78, 94 |
| Texscan | 18, 19 |
| Tocom | 01, 33, 34, 42, 48, 49, 91 |
| Toshiba | 36 |
| Unika | 01, 29, 44, 88, 91 |
| Universal | 42, 43, 44, 52, 63, 88 |
| Viewstar | 13, 20, 22, 26, 40, 58, 62, 98 |
| Videoway | 07, 23, 50 |
| Zenith | 07, 23, 50 |

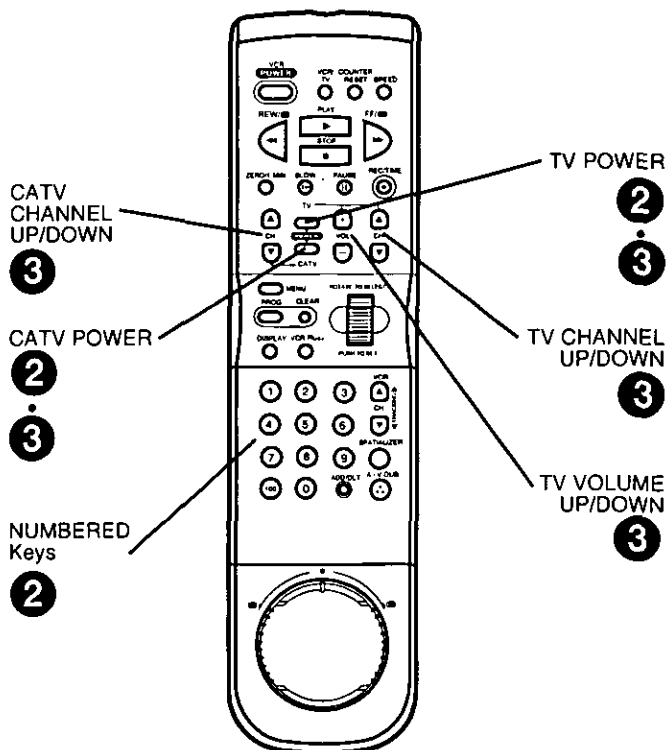

1 Find your TV or Cable Box Brand Code Numbers.

- See left chart for TV or Cable Box Brand Code Numbers.

2 Hold down TV POWER or CATV POWER.

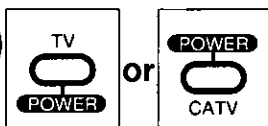

and

Use the **NUMBERED** keys to enter code number.

- Enter your TV or Cable Box brand code number.
- Due to changes in infra-red commands used by some manufacturers, some TV or Cable Box brands are listed more than once. If your TV or Cable Box does not respond in step 3 with the first code, please try entering the next code.

3 Try each of the following functions.

- Some TV and Cable Box brands require you to turn on the power manually.

| (TV) | (Cable Box) |
|-----------------|-----------------|
| POWER ON/OFF | POWER ON/OFF |
| CHANNEL UP/DOWN | CHANNEL UP/DOWN |
| VOLUME UP/DOWN | |

- Depending on your TV or Cable Box model, not all functions listed may be controlled by this remote.



- Please repeat the TV/ Cable Box Set Up procedure when you replace the remote's batteries.
- The remote control is designed to control the brands listed. However, it will not operate all TVs or Cable Boxes made by these manufacturers. If you get no results, your particular product brand cannot be controlled by this remote.



Before Requesting Service

Check the following points once again if you are having some trouble with your VCR.

| Power | Correction |
|---|---|
| No power... | <ul style="list-style-type: none">• Check that the Power Plug is completely inserted to an AC outlet.• Check that the POWER button is set to on. |
| Recording & Playback | Correction |
| TV program can't be recorded... | <ul style="list-style-type: none">• Check the connections between the VCR, the external antenna, and your TV.• Check that the band selected matches your antenna or cable TV system. (P.17)• Make sure that the record tab on the back of the cassette is still intact. (P.5) |
| Timer recording can't be performed... | <ul style="list-style-type: none">• Set the recording start/stop times correctly. (P.22)• Make sure that the POWER button is set to off. (P.22)• Timer recording may not be performed or continued if a power interruption of more than 1 minute occurs before, or during, Timer Recording, even if power resumes thereafter. |
| There is no playback picture, or the playback picture is noisy or contains streaks.. | <ul style="list-style-type: none">• Select the same channel on your TV as that of the Channel 3/4 switch located on the rear panel of the VCR. (P.6)• Set the VCR/TV selector to "VCR". (P.19)• Check that channel 3 or 4 of the TV is properly adjusted.• Adjust the TRACKING control slowly in either direction. (P.19) |
| During special effects playback, the picture may contain some vertical jitter when using a TV which has an Automatic Vertical Hold Control... | <ul style="list-style-type: none">• Set the TV's Vertical Hold Control to "MANUAL" and then adjust it. |
| If the top of your playback picture waves back and forth excessively... | <ul style="list-style-type: none">• Because the VCR playback signal is not as stable as an off-the-air TV signal, the top of your TV screen may be bent or unstable during playback. To solve this problem, slowly turn the horizontal hold control on your TV to correct the wavy picture. If your TV does not have a horizontal hold control or adjusting the control does not help, please contact your local TV service center. |
| VCR can't be controlled... | <ul style="list-style-type: none">• Make sure that VCR LOCK is set to off. (P. 34) |

| Remote Control | Correction |
|---|---|
| VCR can't be remote controlled... | <ul style="list-style-type: none"> • Aim the Remote Control directly at the remote sensor on the VCR. (Refer to Back Cover.) • Avoid all obstacles which may interfere with the signal path. • Inspect or replace the batteries (P.4). • Make sure that VCR LOCK is set to off. (P. 34) • Exposing the VCR remote sensor to direct fluorescent or outdoor light may cause signal interference. |
| Miscellaneous | Correction |
| <p>You can't view programs normally on TV...</p> <p>Video cassette can't be inserted...</p> <p>Video cassette can't be removed...</p> <p>Video cassette ejects when the REC and PLAY buttons are pushed or when the POWER button is pushed off to set the Timer...</p> <p>In the stop mode, the motor (CYLINDER) continues to rotate...</p> <p>VCR can't be controlled...</p> | <ul style="list-style-type: none"> • Set the VCR/TV selector to "TV". (P.20) • Insert the cassette with the window side up and the record tab facing you. • Check that the power plug is completely connected to an AC outlet. • Make sure the record tab on the back of the cassette is still intact. (P.5) • To enable the quick play mechanism, the cylinder will rotate for about 5 minutes. • The quick play mechanism reduces response time from stop to PLAY mode from PLAY to REWIND search mode. • Make sure that VCR LOCK is set to off. (P. 34) |

Fijación del Idioma de la pantalla, fijaciones para la conexión con la caja de TV por cable y receptor DSS, memorizar los canales y fijación automática de la hora.

1  Encienda el televisor y la videograbadora.

2 El televisor debe estar fijado al mismo canal que ha seleccionado en la parte trasera de la videograbadora (canal 3 o 4).

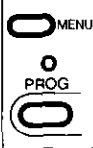
3  Oprimir MENU para elegir "YES" (Sí) o PROG para "NO."

ARE YOU USING A CABLE BOX OR DSS RECEIVER?

PUSH MENU KEY : YES
PUSH PROG. KEY : NO

- Si ha elegido "YES" (Sí), continúe al paso siguiente. Si ha elegido NO, siga las instrucciones alternativas de la página 40.

4  Girar y oprimir la rueda para elegir la conexión de su equipo.

- CABLE/DSS BOX SET UP -
SELECT YOUR CABLE BOX OR DSS RECEIVER SET UP.

CABLE/DSS BOX-VCR-TV
VCR-CABLE/DSS BOX-TV

SELECT : ROTATE WHEEL
SET : PUSH WHEEL
END : PUSH MENU KEY

- Si es "CABLE/DSS BOX-VCR-TV", continúe pase al paso 5. Si ha elegido NO, siga las instrucciones alternativas de la página 40.

5  Girar y oprimir la rueda para fijar el canal de salida de la caja de TV por cable o el receptor DSS (el canal sintonizado en el televisor para ver la emisión de la caja de TV por cable o receptor DSS).

- CABLE/DSS BOX SET UP -
ENTER CABLE BOX OR DSS RECEIVER OUTPUT CHANNEL.

02

SELECT : ROTATE WHEEL
SET : PUSH WHEEL
END : PUSH MENU KEY

- Si está usando los dos, fije el canal de salida del receptor DSS.
- Si ud. está usando los terminales de audio/video, elija y fije a "SALIDA DE VIDEO" para el canal de salida.

6  Girar y oprimir la rueda para elegir "YES" (Sí) o "NO".

- CABLE/DSS BOX SET UP -
DOES YOUR CABLE BOX OR DSS RECEIVER HAVE WIRELESS REMOTE CONTROL?

YES
NO

SELECT : ROTATE WHEEL
SET : PUSH WHEEL
END : PUSH MENU KEY

- Si ha elegido "YES" (Sí), continúe al paso siguiente. Si ha elegido "NO", siga las instrucciones alternativas de la página 40.

7  Girar y oprimir la rueda para fijar el número de código de la caja de TV por cable o receptor DSS que coincide con su marca desde la lista de la página 13.

- CABLE/DSS BOX SET UP -
CHOOSE A CODE NUMBER FOR CABLE BOX/DSS RECEIVER FROM THE LIST IN OWNER'S MANUAL AND ENTER NUMBER.

02

SELECT : ROTATE WHEEL
SET : PUSH WHEEL
END : PUSH MENU KEY

- Este determinará si la videograbadora controlará la caja de TV por cable o el receptor DSS.

8 Si ud. usa una caja de TV por cable, sintonice al canal 2. Si usa un receptor DSS, sintonice a cualquier canal fuera de 200.

Caja de TV

- CABLE/DSS BOX SET UP -
PLEASE TUNE YOUR CABLE BOX TO CH02.

Receptor DSS

PLEASE TUNE YOUR DSS RECEIVER TO CH 270.

PROCEED : PUSH WHEEL
END : PUSH MENU KEY

 Oprimir la rueda para continuar.

9  Girar y oprimir la rueda para elegir "YES" (Sí) o "NO".

Caja de TV

- CABLE/DSS BOX SET UP -
IS YOUR CABLE BOX RECEIVING CH 09 ?

YES
NO

Receptor DSS

IS YOUR DSS RECEIVER RECEIVING CH 200?

YES
NO

SELECT : ROTATE WHEEL
SET : PUSH WHEEL
END : PUSH MENU KEY

Si ud. usa una caja de TV por cable y ha elegido "YES" (Sí), siga al paso 10.
Si ud. usa un receptor DSS y ha elegido "YES" (Sí), siga las instrucciones alternativas de la página 40.
Si ha elegido "NO", aparecerá de nuevo la pantalla del paso 7. Intente fijar un código diferente para su marca y/o cambie la conexión de su equipo.
Si su respuesta es todavía "NO", el control de la caja de TV por cable o el receptor DSS no es disponible. Oprimir MENU y pase a las instrucciones alternativas de la página 40.

10



Girar y oprimir la rueda para elegir y fijar el canal PBS de su local que está recibiendo en su caja de TV por cable.

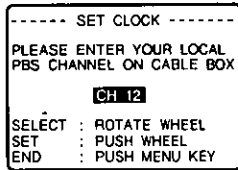

- Si ud. vive cerca de una zona con diferente hora, fije el canal de su zona.

11

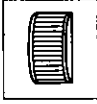

Verifique que su caja de TV por cable esté encendido y su receptor DSS esté apagado.

Oprimir la rueda para iniciar la fijación automática de los canales.

- Las siguientes informaciones aparecerán seguidamente:
 "CH AUTO SET PROCEEDING"
 (AUTOPROGRAMACION EN PROCESO)
 "CH AUTOSET COMPLETED"
 (AUTOPROGRAMACION COMPLETO)
 "AUTO CLOCK SET PROCEEDING"
 (FIJACION AUTOMATICA DEL RELOJ EN PROCESO)

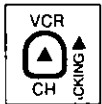

Esta pantalla aparece cuando la fijación automática del reloj es incompleto.

Comprobar si la hora está fijada correctamente y luego oprimir VCR CH ▲ para terminar la fijación.

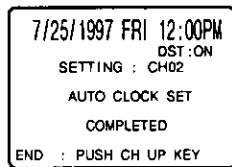

Si la hora fijada automáticamente es incorrecto

Si ud. usa una caja de TV por cable y recibe emisiones de más de un canal PBS, intente fijar automáticamente otravez. Siga los pasos de la fijación o anulación de la hora y cuando las instrucciones de la pantalla requiere la fijación del canal PBS, fije un canal que no ha intentado anteriormente.

Si aparece en la pantalla FIJACION DEL RELOJ INCOMPLETO

La pantalla a la derecha aparecerá si no es displonible en zona la fijación automática de la hora.

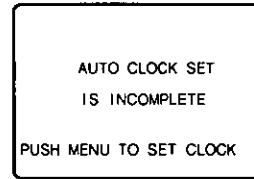

Oprimir MENU para ver la pantalla de la fijación manual del reloj. (Consulte la "Fijacion Manual del reloj" en la página 40).

Notas:

Si ud. usa una caja de TV por cable y recibe emisiones de más de un canal PBS, ud. debe salir desde la pantalla de la fijación del reloj manual e intente fijar automáticamente otravez. Siga los pasos de la fijación o anulación de la hora y cuando las instrucciones de la pantalla requiere la fijación del canal PBS, fije un canal que no ha intentado anteriormente.

- La fijación automática de la hora se efectuará cada día al apagar la videograbadora por primera vez. Si ud. usa una caja de TV por cable y desea efectuar la fijación automática de la hora, la caja de TV por cable debe permanecer encendido cuando la videograbadora se apaga.

Instrucciones alternativas

Complete los siguientes pasos si ha efectuado una de las siguientes explicaciones durante su fijación.

- A Ud. ha elegido NO en el paso 3 de la página 38 (ud. no está usando una caja de TV por cable o un receptor DSS).
- B Ud. ha elegido la segunda conexión (VCR-CABLE/DSSBOX-TV) en el paso 4 de la página 38.
- C Ud. ha elegido NO en el paso 6 de la página 38 (su caja de TV por cable o receptor DSS no tiene un control remoto).
- D Ud. está usando un receptor DSS y ha elegido SI en el paso 9 de la página 38.
- E No se puede controlar la caja de TV por cable o receptor DSS en el paso 9 de la página 38.

- 1** Encienda la caja de TV por cable y fije la caja de TV por cable al canal PBS de su zona.

- Si ud. vive cerca de una zona con diferente hora, asegúrese de fijar el canal de su zona.
- Si ud. usa un receptor DSS, éste debe estar apagado.

CHANNEL/CLOCK AUTO SET
CONNECT ANTENNA CABLE AND IF YOU USE A CABLE BOX, TUNE IT TO YOUR LOCAL PBS CH THEN...
PLEASE PUSH CH UP KEY

- 2** Oprimir VCR CH ▲ para iniciar la fijación automática de los canales.

- Las siguientes informaciones aparecerán seguidamente:
"CH AUTO SET PROCEEDING"
(AUTOPROGRAMACION EN PROCESO)
"CH AUTOSSET COMPLETED"
(AUTOPROGRAMACION COMPLETO)
"AUTO CLOCK SET PROCEEDING"
(FIJACION AUTOMATICA DEL RELOJ EN PROCESO)

Esta pantalla aparece para informarle que la fijación automática de la hora es incompleto.

- 3** Comprobar si la hora está fijada correctamente y luego oprimir VCR CH ▲ para terminar la fijación.

Si aparece esta pantalla, la fijación automática no es disponible en su zona. Por favor fije la hora manualmente como describe al siguiente.

7/25/1997 FRI 12:00PM
DST: ON
SETTING : CH02
AUTO CLOCK SET
COMPLETED
END : PUSH CH UP KEY

AUTO CLOCK SET
IS INCOMPLETE
PUSH MENU TO SET CLOCK

Si la hora y la hora veraniega es incorrecta, por favor siga los siguientes pasos:

Raras veces, en caso de que ud. vive cerca de dos zonas con hora diferente, el aparato puede elegir un canal PBS con diferente hora de su zona. En este caso, haga los siguientes pasos:

- 1 Tome nota del canal que está fijado en la pantalla y salga desde este modo oprimiendo el botón VCR CH ▲.
- 2 Anule este canal desde los canales memorizados en la combinación de VCR/TV.
- 3 Oprima el botón MENU para que aparezca la pantalla del MENU.
- 4 Use la rueda para elegir "SET CLOCK" (Fijar reloj) y luego para elegir "AUTO SET" (Auto matico).
 - Si ud. esta usando una caja de TV por cable y tiene muchos canales PBS, sintonice la caja de TV por cable a un canal PBS diferente e intente la fijación automática otravez.

Fijación manual del reloj

- 1 Oprimir MENU para que aparezca la pantalla de la fijación del reloj.
- 2 Girar y oprimir la rueda para elegir y fijar el mes, la fecha, el año, la hora y la hora veraniega.

SET CLOCK
DST: ON
SELECT MONTH BY ROTATING WHEEL
PUSH WHEEL →
TO END PUSH MENU KEY

Para hacer correcciones

Oprimir la rueda o el botón CLEAR repetidamente para retroceder o avanzar hasta el paso que desea corregir.

- 3 Oprimir MENU dos veces para iniciar a funcionar el reloj y salir desde este modo.

SET CLOCK
2/7/1997 FRI 1:30PM
DST: ON
SET COMPLETED
TO CORRECT PUSH WHEEL OR CLEAR KEY TO START PUSH MENU KEY

Fijación o cambio de la hora



En caso de que el reloj está incorrecto o ha ocurrido un corte eléctrico.

- 1 Oprimir MENU para que aparezca la pantalla del menú.
- 2 Girar y oprimir la rueda para elegir la pantalla de la fijación del reloj y luego fijar la hora y la fecha.
- 3 Oprimir MENU dos veces para iniciar a funcionar el reloj y salir desde este modo.

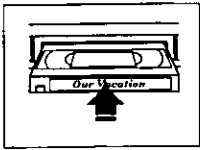

MENU
SET UP VCR
SET CLOCK
SET UP CHANNEL
SELECT : ROTATE WHEEL
SET : PUSH WHEEL
END : PUSH MENU KEY

SET CLOCK
2/7/1997 FRI 1:30PM
DST: ON
SELECT MONTH BY ROTATING WHEEL
PUSH CLEAR : PUSH WHEEL
TO START PUSH MENU KEY

Operaciones básicas para la reproducción

- 1**  Introducir una cinta
- La videgrabadora se enciende automáticamente.
- 
- Esta indicación aparece en la pantalla multifuncional.

- 2**  Oprimir PLAY para comenzar a reproducir.
- Si la cinta no tiene la lengüeta para evitar borrado la videgrabadora comienza a reproducir automáticamente.
- (Videgrabadora o Control Remoto)

- 3**  o  Oprimir REW o FF para localizar rápidamente una escena.
- (Videgrabadora o Control Remoto)
- La velocidad de búsqueda en el modo SP es a 9 veces más rápida que la velocidad normal y en el modo SLP es a 27 veces más rápida.
 - Durante la búsqueda aparece alguna barras de ruido.

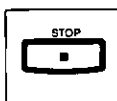
- 4**  Oprimir STOP para parar la reproducción.
- (Videgrabadora o Control Remoto)

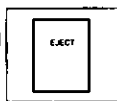
- 5**  Oprimir EJECT para expulsar la cinta.
- Este botón se encuentra solamente en la videgrabadora.

Operaciones básicas para la grabación

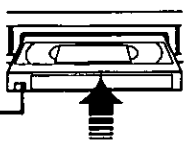
- 1**  Introducir una cinta con la lengüeta.
- La videgrabadora se enciende automáticamente.

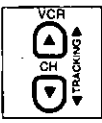
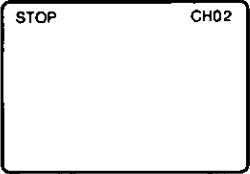
- 2**  Oprimir VCR CH ▲/▼ para elegir el canal.
- 
- U oprimir CHANNEL ▲/▼ en la videgrabadora.
 - Para grabar desde una fuente externa, oprimir VCR CH ▲/▼ para elegir LINEA1 ou LINEA2.

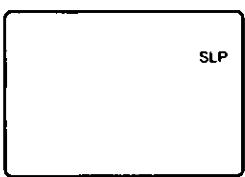
- 3**  Oprimir SPEED para cambiar la velocidad de la cinta.
- 
- SP = Reproducción estándar, LP = Larga duración, SLP = Superlarga duración.

- 4**  Oprimir REC/TIME con el control remoto para empezar a grabar.
- U oprimir PLAY y REC/TIME en la videgrabadora.

Grabación de un toque (OTR)

La videgrabadora termina la grabación a una hora programada.

Oprima sucesivamente REC/TIME para fijar el tiempo de la grabación.

Cada presión cambiará la hora de parada como demuestra al siguiente.

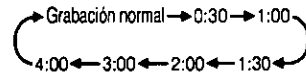

- La indicación TIMER aparece en la pantalla multifuncional.

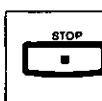
- 5**  Oprimir STOP para parar la grabación.
- U oprimir STOP en la videgrabadora.

- Si mantiene oprimiendo el botón de VCR CH ▲/▼ aumentará la velocidad del cambio del canal.
- Oprimir PAUSE para hacer una pausa en la grabación en progreso.

Programación fácil para la grabación con temporizador

- 1**  Oprimir PROG para que aparezca la pantalla de la programación.

- Si ya existe una programación, elija usando la rueda un número sin programación.

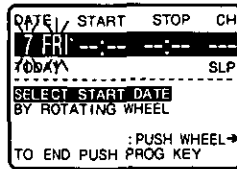

- 2**  Girar y oprimir la rueda para elegir y fijar la fecha.

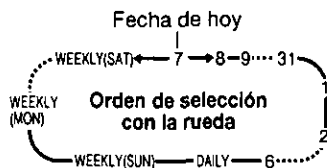

Grabación diaria y semanal

Si ud. desea programar una grabación diaria (lunes a viernes), elija DAILY (Diario) en vez de la fecha en el paso 2. Si desea una grabación semanal, elija WEEKLY MAN (Semanal Lun), TUE (Mar), etc.

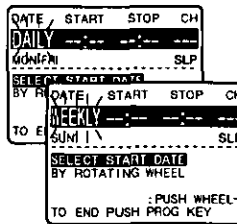

- 3**  Girar y oprimir la rueda para elegir y fijar las fijaciones que sobran.

Fijaciones:

- Hora de inicio • Hora de parada
- Canal o LINEA para una fuente externa .
- Velocidad de la cinta (SP, LP, SLP).

Para hacer correcciones

Oprimir la rueda sucesivamente para avanzar u oprimir CLEAR para retroceder hasta el paso que desea corregir.

- 4**  Oprimir PROG para terminar la programación.

- Si desea hacer más programaciones, elija un número de programa en blanco con la rueda y repita los paso 2 y 3.

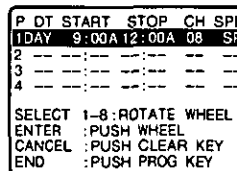

- 5**  Oprimir PROG para salir desde este modo.

- 6**  Oprimir POWER y apague el aparato para la grabación con temporizador.

- Si la fuente de la grabación es una caja de TV por cable, asegúrese de que la caja de TV por cable esté encendido y esté sintonizado al canal que desea grabar.

Pantalla multifuncional



Note

Quick Use Guide

This guide should only be used once you are familiar with the operations inside this manual. If you have any problems or need more information, please refer to the page listed.

Clock Reset (page 14)

Display the menu

ROTATE TO SELECT
PUSH TO SET

Select "SET CLOCK"

ROTATE TO SELECT
PUSH TO SET

Select "MANUAL SET"

ROTATE TO SELECT
PUSH TO SET

Set the clock

Start the clock & exit this mode

Playback a Tape (page 19)

Turn TV on
Select VCR
Channel 3/4

Insert a tape

Start playback

Stop playback

At VCR
Eject tape

Make a Recording (page 20)

Turn TV on
Select VCR
Channel 3/4

Insert a tape
with Record Tab

Select channel

Select speed

Start recording

Stop recording

Set a Timer Recording (page 22)

Enter the Program mode

ROTATE TO SELECT
PUSH TO SET

Enter timer information

Once to finish the program, twice to exit this mode

Turn VCR off to set the timer

Panasonic Latin America S.A.
P. O. BOX 7592 Panama 5, Republic of Panama
Tel: (507)229-2955 Fax: (507)229-2536